

# INTEGRATION OF THE OUTPUT OF A SILICON SOLAR CELL TO THE GRID SYSTEM

***Md. Imran Azim***

Department of Electrical & Electronic Engineering,  
Rajshahi University of Engineering & Technology (RUET), Bangladesh

***Md. Rajibur Rahman***

Department of Electrical & Electronic Engineering,  
University of Information Technology & Sciences (UITS),  
Dhaka, Bangladesh

***Prof. Dr. Md. Fayzur Rahman***

Department of Electronics & Telecommunication Engineering,  
Daffodil International University (DIU), Dhaka, Bangladesh

---

## Abstract

With the advent of the 21<sup>st</sup> century, the utilization of renewable energy in modern power generation has been leapt to a level that was unimaginable only even 100 years ago. Solar energy is one of the popular renewable energy sources as it is abundant in nature especially warm predominant countries like Bangladesh. In addition, some noteworthy upsides of solar energy are free fuel such as sunlight is free, environmental friendly operation, minimal maintenance and longer service life. This paper furnishes knowledge about the performance of a single crystalline silicon solar cell, based on the practical experimental results that have been obtained from different connections of the used modules like single module, series connection of double modules and parallel connection of double modules. The comparative results show that maximum open circuit voltage, maximum output power and maximum fill factor have been obtained from series connection of double modules whereas, parallel connection of double modules has given the largest amount of short circuit current. On the other hand, highest efficiency has been derived in case of single module connection. Besides, suitable arrangements have also been demonstrated in this paper so that the output of these solar modules can be connected to the grid system with a view to meeting up the increased power demand.

---

**Keywords:** Solar Cell, Module, Panel, Open Circuit Voltage ( $V_{oc}$ ), Short Circuit Current ( $I_{sc}$ ), Maximum Power ( $P_{max}$ ), Efficiency, Fill Factor ( $FF$ ), Three Single Phase Inverters and Three Single Phase Transformers.

## Introduction

A solar cell is a device which converts light energy directly into electricity. Light shining on the solar cell produces both a current and a voltage to generate electric power. This process requires a material, in which the absorption of light raises an electron to a higher energy state, and the movement of this higher energy electron from the solar cell into an external circuit. The electron then dissipates its energy in the external circuit and returns to the solar cell. A variety of materials and processes can potentially satisfy the requirements for photovoltaic energy conversion, but in practice, nearly all photovoltaic energy conversion uses semiconductor materials in the form of a p-n junction and that is why a solar cell is known a sandwich of n-type and p-type material (solar-cell-structure).

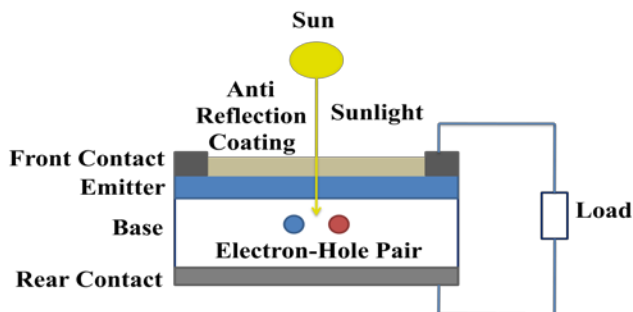

Figure 1. Solar Cell Operation.

The basic steps in the operation of solar cell are:

- Light absorption.
- Generation of light-generated carriers.
- Collection of the light-generated carries to generate a current.
- Generation of a voltage across the solar cell.
- Dissipation of power in the load.

In order to achieve more voltage and power, solar cells are combined and sealed in an environmentally protective laminate to form solar modules. Moreover, the assemblage of two or more solar modules is termed as a solar panel.

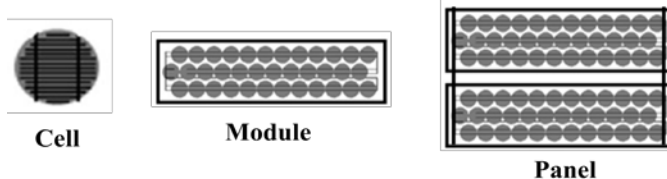

Figure 2. Structure of Solar Cell, Module and Panel (what-are-solar- pannels).

The purpose of grid connected solar system is to generate an optimal amount of electrical energy over a given time, usually one year. This amount depends on the irradiation at the location at which solar system is operating and on the quality of the components used. Another possibility is to supply the local load first and to feed into the grid only when there is a surplus. With recent grid failures, a third option of solar becomes of interest, namely, to function as an energy supply for a back-up system (Goetzberger, U.hoffmann, Springer)

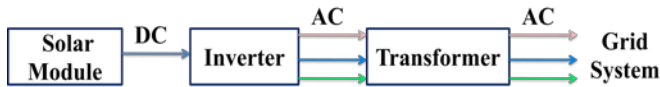

Figure 3. Grid Connection of Solar Energy.

### Mono-crystalline Silicon (C-Si) Solar Cell:

Silicon is the most common material used in solar cell because they are non toxic, abundant in nature, relatively cheap and they mature infrastructure as well. As name implies mono crystalline silicon solar cell is produced from single, pure crystal. It finds extensive applications because of producing more current, having higher lab efficiency compared to other solar cells due to pure and defect free crystals, higher longevity meaning it degrades little over time (monocrystalline).

The open-circuit voltage,  $V_{oc}$  of C-Si solar cell is the maximum voltage available from a solar cell, and this occurs at zero current. The open-circuit voltage corresponds to the amount of forward bias on the solar cell due to the bias of the solar cell junction with the light-generated current. The open-circuit voltage depends on the saturation current of the solar cell and the light-generated current (open-circuit-voltage).

The short-circuit current,  $I_{sc}$  is the current through the solar cell when the voltage across the solar cell is zero. The short-circuit current is due to the generation and collection of light-generated carriers. The short-circuit current depends on a number of factors such as area of solar cell, number of photons, spectrum of incident light, light absorption and reflection and collection property of solar cell (short-circuit-current).

The efficiency,  $\eta$  is the most commonly used parameter to compare the performance of one solar cell to another. Efficiency is defined as the ratio of energy output from the solar cell to input energy from the sun.

$$\eta = \frac{P_{\max}}{P_{in}} \times 100\% \quad (1)$$

In addition to reflecting the performance of the solar cell itself, the efficiency depends on the spectrum and intensity of the incident sunlight and the temperature of the solar cell (efficiency).

The fill factor, more commonly known by its abbreviation *FF*, is a parameter which, in conjunction with  $V_{oc}$  and  $I_{sc}$ , determines the maximum power from a solar cell. The *FF* is defined as the ratio of the maximum power from the solar cell to the product of  $V_{oc}$  and  $I_{sc}$ .

$$FF = \frac{P_{max}}{V_{oc} I_{sc}} \times 100\% \tag{2}$$

The fill factor generally measures the quality of solar cell that is how its performance is compared to an ideal solar cell (fill-factor).

The single crystalline silicon solar cell, used in the laboratory to find  $V_{oc}$ ,  $I_{sc}$ ,  $P_{max}$  possess the following ratings as seen in Table-I,

Parameters	Ratings
Maximum Power, $P_{max}$	85W
Short Circuit Voltage, $V_{oc}$	21.94V
Open Circuit Current, $I_{sc}$	5.29A
Rated Voltage	18.05V
Rated Current	4.71A
Series Fuse	10A
Maximum System Voltage	1000V
Fire Rating	Class C

Azimuth Angle=23°

Each Cell Area = 125mm × 125mm = 0.0156 m<sup>2</sup>

Number of Cells in a Module=36; Number of Modules=2

### Different Configurations of C-Si Solar Cell:

In order to analyze the performance of C-Si solar cell, various connections are made and parameters are measured by solar storage controller. All these are being illustrated below:

1. Single Module Connection: In this connection, only one module was connected. The data, found here have been given in Table-II and simulated in “Fig.5”,

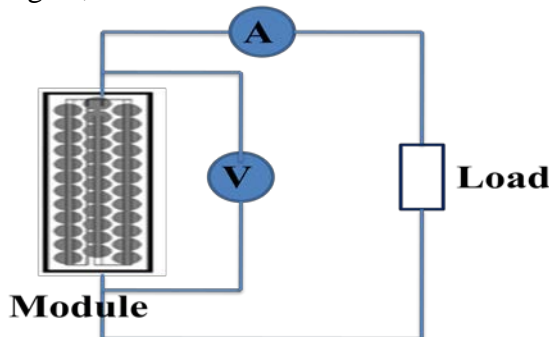

Figure 4. Single Module Connection.

**Table-II. Measured Values of Single Module Connection**

Voltage, $V$ (V)	Current, $I$ (A)	Power= $V \times I$ (W)
0.62	4.57	2.83
5.30	4.51	23.90
9.80	4.47	43.81
13.92	4.31	60.00
16.09	3.64	58.57
17.05	3.00	51.15
17.63	2.50	44.08
17.96	2.16	38.79
18.17	1.93	35.07
18.25	1.85	33.76
18.30	1.82	33.31

Irradiation intensity: 0.80 KW/m<sup>2</sup>; 97000 LUX  
 $V_{oc}$ = 18.3 V;  $I_{sc}$ = 4.57 A;  $P_{max}$ = 60 W

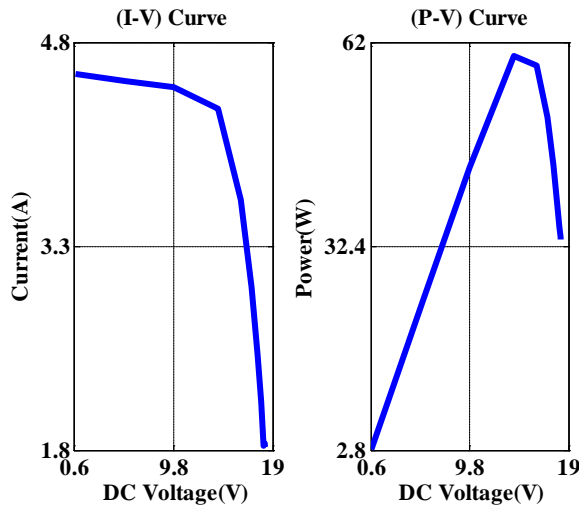

Figure 5. Characteristic Curves of Single Module Connection.

Input Power,  $P_{in}$ = 0.80 × 1000 × (0.0156 × 36) W

From “(1)”, and “(2)”,

The efficiency,  $\eta$  = 13.35%

Fill Factor,  $FF$ =71.74 %

2. Series Connection of Double Modules: Two modules are connected in series in this case. The results have been expounded in Table-III and simulated in “Fig.7”,

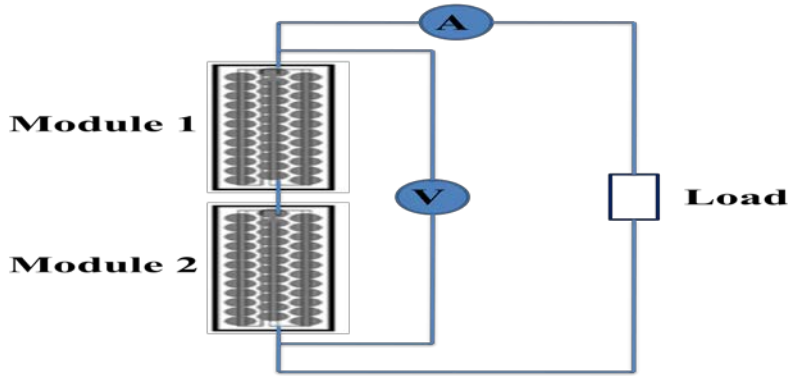

Figure 6. Double Modules Connected in Series Connection.

Table-III. Measured Values of Double Modules Connected in Series

Voltage, $V$ (V)	Current, $I$ (A)	Power= $V \times I$ (W)
0.60	4.47	2.68
6.00	4.46	26.76
11.30	4.45	50.29
16.00	4.42	70.72
21.70	4.39	95.26
26.90	4.28	115.13
29.90	3.95	118.11
31.50	3.63	114.35
32.80	3.27	107.26

Irradiation intensity:  $0.83 \text{ KW/m}^2$ ; 10200 LUX  
 $V_{oc} = 32.8 \text{ V}$ ;  $I_{sc} = 4.47 \text{ A}$ ;  $P_{max} = 118.11 \text{ W}$

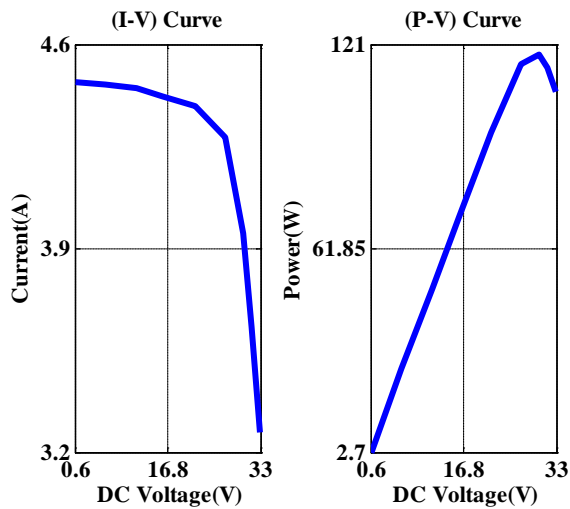

Figure 7. Characteristic Curves of Series Conncted Double Modules.

Input Power,  $P_{in} = 0.83 \times 1000 \times (0.0156 \times 36 \times 2) \text{ W}$

From “(1)”, and “(2)”,

The efficiency,  $\eta = 12.67\%$

Fill Factor,  $FF=80.56 \%$

3. Parallel Connection of Double Modules: It consists of two modules connected in parallel connection. The experimental outputs have been figured out in Table-IV and simulated in “Fig.9”,

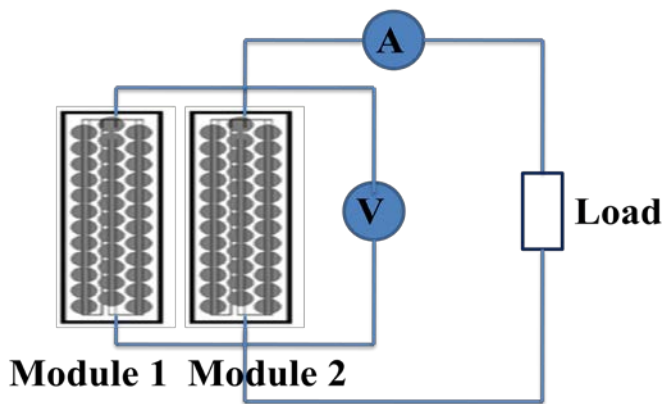

Figure 8. Double Modules Connected in Parallel Connection.

Table-IV. Measured Values of Double Modules Connected in Parallel

Voltage, $V(V)$	Current, $I(A)$	Power= $V \times I(W)$
0.90	8.80	7.92
1.80	8.78	15.81
14.80	7.28	107.74
16.80	4.65	78.12
17.60	3.18	55.97
17.80	2.63	46.81
18.10	2.13	38.55
18.20	1.82	33.12

Irradiation intensity:  $0.81 \text{ KW/m}^2$ ; 9820 LUX

$V_{oc} = 18.2 \text{ V}$ ;  $I_{sc} = 8.8 \text{ A}$ ;  $P_{max} = 107.74 \text{ W}$

Input Power,  $P_{in} = 0.81 \times 1000 \times (0.0156 \times 36 \times 2) \text{ W}$

From “(1)”, and “(2)”,

The efficiency,  $\eta = 11.84\%$

Fill Factor,  $FF=67.23 \%$

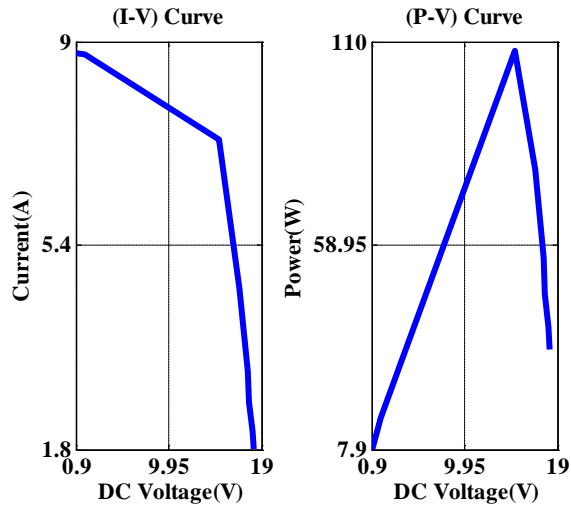

Figure 9. Characteristic Curves of Parallely Conncted Double Modules.

### Grid Connection of Derived Solar Energy From Various Connections:

Grid connected solar systems always have a connection to the public electricity grid via a suitable inverter and transformer because a solar module delivers only dc power. Normally there are almost no effects of the solar systems on the grid affecting power quality, load-on lines, transformers and so on. However, for a larger share of solar in low voltage grids, these effects are needed to be taken into account. From technical point of view, there will be no difficulty in integrating as much solar into low voltage grids (Voss K et al. 2002)

**a. DC to AC Conversion by Inverter:** Grid connected converters are required to transfer harvested green energy from solar systems into the main grid. The first grid connected inverters were based on Silicon Controlled Rectifiers (SCR) technology which were also limited in control and came with a high harmonic content, making the use of bulky inefficient filters necessary. With the introduction of MOSFETS for the lower power area and IGBT's for the high power applications, the control of grid side inverters has become more advanced. The primary concern in grid converter design is the efficiency, due to the costs of solar produced energy (P. J. van Duijsen). Significant research and development in the area of pulse width modulated inverters has been done in attempt to reduce the passive filter size and create a better sinusoidal output, thus reducing harmonics (Pritam Chowdhury, 2013).



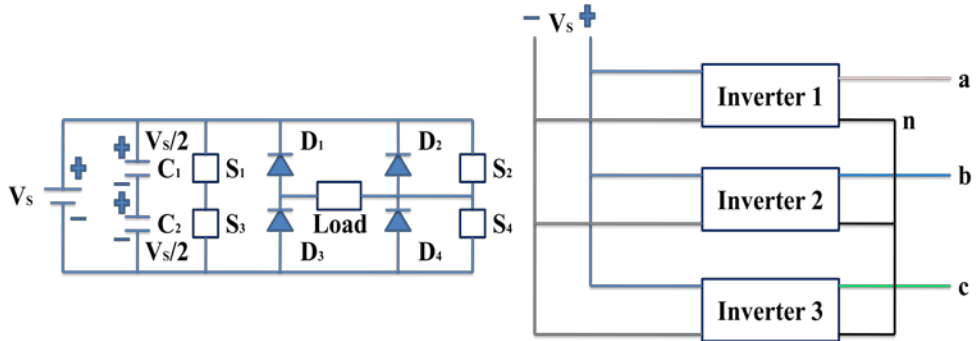

Figure 10. Three Single Phase Full Bridge Inverters (H. Rashid, 2006).

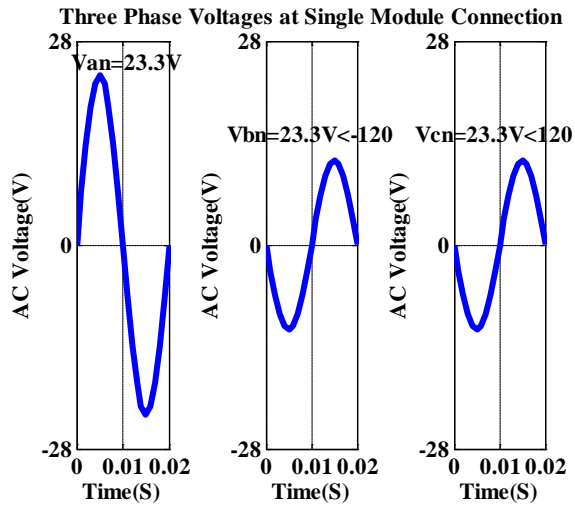

Figure 11. Inverted Phase Voltages Obtained from Single Module Connection.

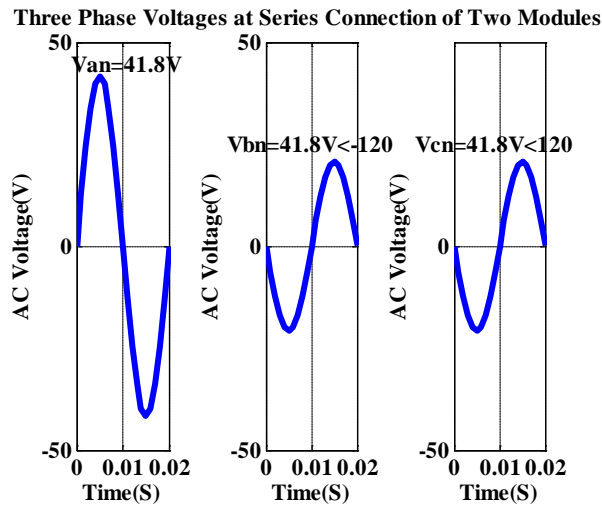

Figure 12. Inverted Phase Voltages Obtained from Series Connection of Double Modules .

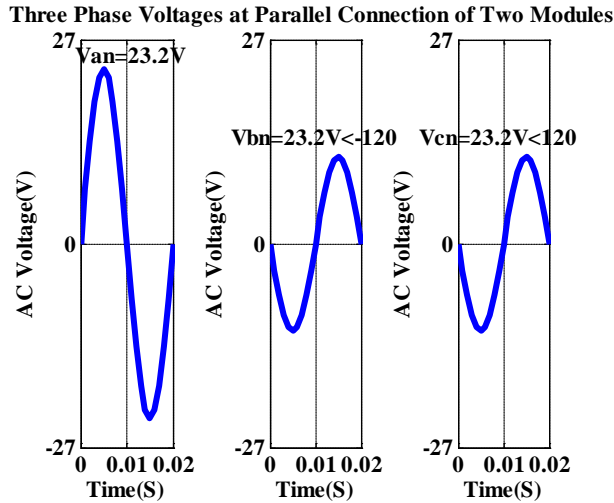

Figure 13. Inverted Phase Voltages Obtained from Parallel Connection of Double Modules.

Table-V. Derived Voltages in Considered Configurations

Connections	Solar DC Voltages (V)	Inverted AC Voltages (V)
Single Module	18.3	23.3
Double Module Series	32.8	41.8
Double Modul Parallel	18.2	23.2

**b. Transformation of AC Phase Voltages to the Balanced Phase Voltages:** The balanced Phase to neutral voltage here in Bangladesh is 230V. Therefore, different transformers are used in different connection to boost up the voltage magnitude.

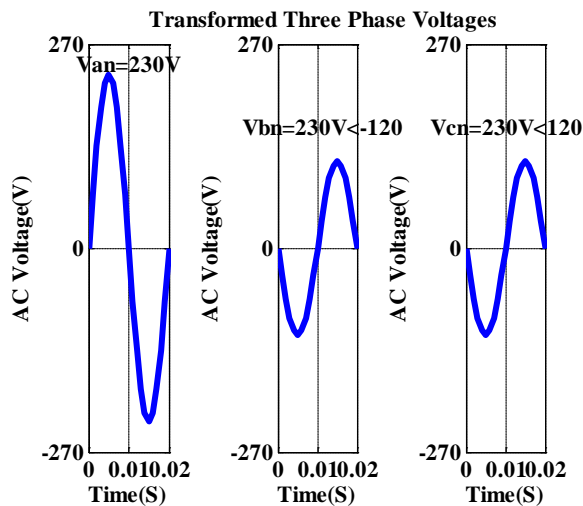

Figure 14. Balanced Three Phase Voltages in the Context of Bangladesh.

## **Conclusion:**

The proposed strategy focuses on the advantages that can be achieved from connecting the solar modules in numerous ways. It has been found that when only one module is used in the experiment, maximum efficiency, approximately 13.5% is obtained. Furthermore, maximum fill factor is 80.56% which has been got if another module is added in series connection. Moreover, it is the double module parallel connection from which largest amount of power can be supplied to the grid network in comparison with other connections.

However, single crystalline silicon solar cell suffers from some downsides as it requires large amount of silicon and high temperature for manufacturing process. Even, it is expensive and fragile. The implementation of polycrystalline and amorphous solar cell would diminish these disadvantages to a considerable extent although there is a chance of reducing the cell efficiency. Another fact is that the appendage of three single transformers that may cause 1%-3% core loss and therefore, decreases the efficiency while supplying the inverted power to the grid system. In this situation, the implementation of boost converter would be great in future.

## **References:**

- Solar-cell-structure, open-circuit-voltage, short-circuit-current, efficiency, fill-factor, <http://pveducation.org/pvcdrom/solar-cell-operation> what - are solar - panels, monocrystalline, <http://www.solar-facts-and-advice.com>
- Goetzberger, V.U.hoffmann, Photonic Solar Energy Generation, Springer.
- Voss K et al., Building energy concepts with photovoltaics-Concept and examples from Germany, Advances in Solar Energy, 2002, pp.235.
- P. J. van Duijsen, Modeling Grid Connection for Solar and Wind Energy, Simulation Research, The Netherlands, Frank Chen, Pitotech, Taiwan, pp.1-6.
- Pritam Chowdhury, ndrajit Koley, Sougata Sen, Dr.Pradip Kumar Saha, Dr.Gautam Kumar Panda, “Modelling, Simulation and Control of a Grid Connected non-conventional Solar Power generation System Using MATLAB”, International Journal of Advanced Research in Electrical, Electronics and Instrumentation Engineering, Vol. 2, Issue 4, April 2013, pp.1183-1191.
- Muhammad H. Rashid, Power Electronics Circuits, Devices, and Applications Third Edition. Dorling Kindersley Pvt. Ltd. 2006.