

# FORMULATION OF THE INTERNAL STRESS EQUATIONS OF PINNED PORTAL FRAMES PUTTING AXIAL DEFORMATION INTO CONSIDERATION

***Okonkwo V. O.***

B.Eng, M.Eng, MNSE, COREN.Lecturer, Department of Civil Engineering, Nnamdi Azikiwe University, Nigeria.

***Aginam C. H.***

B.Eng, M.Eng, Ph.D. MNSE, MNIStruct. E, COREN.Senior Lecturer, Department of Civil Engineering, Nnamdi Azikiwe University, Nigeria

***Ezeagu A. C***

B.Eng, M.Eng, Ph.D, MNSE, MNIStruct. E, MNICE, COREN.Lecturer, Department of Civil Engineering, Nnamdi Azikiwe University, Nigeria

---

## Abstract

In this work the internal stress equations for pinned portal frames under different kinds of loading was formulated using the equilibrium method. Unlike similar equations in structural engineering textbooks these equations considered the effect of deformation due to axial forces. This effect was captured in a dimensionless constant  $s$ , when  $s$  is set to zero, the effect of axial deformation is removed and the equations become the same as what can be obtained in any structural engineering textbook. An investigation into the effect of axial deformation on the internal stresses and its variation with the ratios of second moment of areas of the horizontal and vertical members of the frame ( $I_2/I_1$ ) and the ratio of height to length of the portal frame ( $h/L$ ) showed that the effect of axial deformation is appreciable and cannot be neglected in vertically loaded portal frames and in frames subjected to significant horizontally distributed loads.

---

**Keywords:** Pinned Portal frames, axial deformation, flexural rigidity, stiffness matrix

**Introduction**

Portal frames are the most frequently used structural forms for single storey buildings. They are usually made of steel but can be made of concrete or timber. It is estimated that around 50% of the hot-rolled constructional steel used in the UK is fabricated into single-storey buildings (G. Raven & A. Pottage 2007). This no doubt shows the growing importance of this structural unit. Computer analysis of structures has taken the central stage in the analysis of structures (Samuelsson and Zienkiewi, 2006) and many computers programs incorporate the effect of axial deformation (Saikat,2001). However, many simple structures like portal frames are still analyzed manually using equations found in structural engineering textbooks and design manuals (Reynold and Steedman, 2001). These equations are very useful and can be used to check computer results (Hibbeler, 2006). These equations were however formulated without any consideration for the effect of axial deformation on the internal stresses hence the need for the development of equations that capture the contribution of axial deformation in the analysis of portal frames for different loading conditions.

**Using the Flexibility Method**

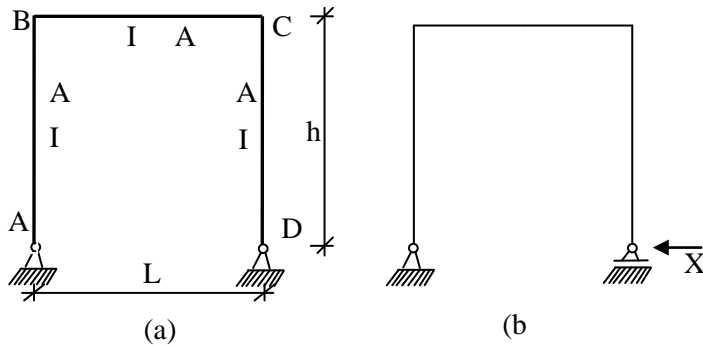

Figure 1: The Basic System showing the removed redundant force

The basic system or primary structure for the structure in Figure 1a is given in Figure 1b. The removed redundant force is depicted with  $X_1$ . The flexibility matrix of the structure can be determined using the principle of virtual work.

By applying the unit load theorem the deflection in beams or frames can be determined for the combined action of the internal stresses, bending moment and axial forces with

$$D = \int \frac{\bar{M}M}{EI} ds + \int \frac{\bar{N}N}{GA} ds \dots\dots\dots(1)$$

Where  $\bar{M}$  and  $\bar{N}$  are the virtual internal stresses while  $M$  and  $N$  are the real/actual internal stresses.

$E$  is the modulus of elasticity of the structural material

$A$  is the cross-sectional area of the element

G is the modulus of elasticity in shear,  $G = \frac{E}{2(1+\nu)}$  where  $\nu$  is poisson's ratio(Ghali et al, 1985).

If  $d_{ij}$  is the deformation in the direction of i due to a unit load at j then by evaluating equation (1).

$$d_{11} = \frac{h(2h^3I_2A_2+3h^2U_1A_2+3U_1I_2)}{3EI_1I_2A_2} \dots\dots\dots(2)$$

The structure's compatibility equation can be written thus

$$d_{10} + X_1d_{11} = 0 \dots\dots\dots(3)$$

Where  $X_1$  is the redundant force and  $d_{10}$  is the deformation due to external load on the basic system (reduced structure) .

$$X_1 = -d_{10}/d_{11} \dots\dots\dots(4)$$

Equation (4) is evaluated to get the redundant force and this is substituted into the structure's force equilibrium (superposition) equation to obtain the internal stress at any point.

$$M = M_o + M_1X_1 \dots\dots\dots(5)$$

Where M is the required stress at a point,  $M_o$  is the stress at that point for the reduced structure,  $M_1$  is stress at that point when the redundant force  $X_1=1$  acts on the reduced structure.

For the loaded portal frame of Figure 2, the deformation of the reduced structure due to external load is

$$d_{10} = -\frac{ql^3h}{12EI_2} \dots\dots\dots(6)$$

By substituting the value of equation (6) into equations (4)

$$X_1 = \frac{wl^3(I_1A_{1r})}{4(2h^3I_2A_2+3h^2U_1A_2+3U_1I_2)} \dots\dots\dots (7)$$

Evaluating equation (5) for point B and C on the structure using the force factor obtained in equation (7)

$$M_B = M_C = \frac{-wl^3h^2(I_1A_2)}{4(2h^3I_2A_2+3h^2U_1A_2+3U_1I_2)} \dots\dots\dots(8)$$

For the loaded portal frame of Figure 3, the deformation of the reduced structure due to external load is

$$d_{10} = \frac{-whl^3}{24EI_2} \dots\dots\dots(9)$$

By substituting the value of equation (9) into equations (4)

$$X_1 = \frac{wl^3hl_1A_2}{8(2h^3I_2A_2+3h^2U_1A_2+3U_1I_2)} \dots\dots\dots(10)$$

Evaluating equation (5) for point B and C on the structure using the force factor obtained in equations (10)

$$M_B = M_C = -\frac{wh^2l^3I_1A_2}{8(2h^3I_2A_2+3h^2U_1A_2+3U_1I_2)} \dots\dots\dots(11)$$

This process was repeated for other loaded portal frames and the results are presented in Table 1.

**Discussion of Results**

The internal stress (Bending Moments) on the loaded portal frames is summarized in table 1. The effect of axial deformation is captured by the dimensionless constant  $s$  and is taken as the ratio of the end translational stiffness to the axial stiffness of a member.

$$s_1 = \frac{12I_1}{h^2A_1} \dots\dots\dots(12)$$

$$s_2 = \frac{12I_2}{l^2A_2} \dots\dots\dots(13)$$

When  $s_1 = 0$ , the effect of axial deformation in the columns is ignored and likewise when  $s_2 = 0$ , the effect of axial deformation in the beams is ignored.

The internal stress equations enable an easy calculation of the internal stresses on pinned portal frames under different kinds of loads but this time putting axial deformation into consideration.

The contribution of axial deformation is calculated by evaluating the equations in table 1 less the equivalent values when axial deformation is neglected. This was expressed as a percentage of the moment values when shear is considered. It is possible to express all the internal stress equations in terms of the ratios  $h/L$  and  $I_2/I_1$ . This way the variation of axial

contribution with these parameters was investigated. Figure 4 shows a plot of the percentage (%) change in internal stresses (Bending moment) of frames 1, 2 and 7 versus the ratio of beam second moment of area to column second moment of area ( $I_2/I_1$ ). From the plot it would be observed that the percentage (%) contribution of axial deformation in vertically loaded pinned portal frames is

- i. Constant for any value of the ratio  $I_2/I_1$ .
- ii. Negative i.e. the effect of axial deformation reduces the expected internal stresses (bending moment).
- iii. Increases linearly with increasing values of the ratio  $I_2/I_1$ .

Figure 5 shows a similar plot of the percentage (%) change in internal stresses (bending moment) versus the ratio of height to length of portal frame ( $h/L$ ). From the plots it can be inferred that the percentage (%) contribution of axial deformation in vertically loaded pinned portal frames is

- i. Constant for any value of the ratio  $h/L$ .
- ii. Negative i.e. the effect of shear deformation reduces the expected internal stresses (bending moment).

- iii. Decreases exponentially with increasing values of the ratio  $h/L$ . At  $h/L > 1.0$ , the contribution of axial deformation is practically zero.

Figure 6 shows a plot of the percentage (%) change in internal stresses (bending moment) of frames 3,4,5 and 6 versus the ratio of beam second moment of area to column second moment of area ( $I_2/I_1$ ). From the

plot it can be deduced that the percentage (%) contribution of axial deformation in these frames

- i. Is positive, i.e. the effect of axial deformation increases the expected internal stresses (bending moment).
- ii. Is less than 10% for  $I_2/I_1 \leq 1$ .
- iii. Is more than 10% but not beyond 15% at  $I_2/I_1 > 5$  except for frame 3.
- iv. Is close to 0% and hence insignificant for frame 6.

Figure 7 shows a plot of the percentage (%) change in internal stresses (bending moment) of frames 3,5,6 and 8 versus the ratio of height to length of portal frame

( $h/L$ ). From the plot it can be deduced that the percentage (%) contribution of axial deformation in these frames

- i. Is almost zero (0%) at  $h/L \geq 1.0$ .
- ii. Is positive at  $h/L < 1.0$ .
- iii. Is less than 10% at  $h/L < 1.0$  except for frame 3 where it rose exponentially to 35% at very small values of the ratio  $h/L$ .

### Conclusion

Table 1 contains simple equations that can be used for the computation of the internal stresses (bending moments) in pinned portal frame putting the effect of axial deformation into consideration.

An investigation of the variation of the effects of axial deformation with the ratios of beam second moment of area to column second moment of area ( $I_2/I_1$ ) and the ratio of height to length of portal frame ( $h/L$ ) shows that:

1. For vertically loaded portal frames with the ratio  $I_2/I_1 > 1$  the effect the axial deformation reduces the calculated internal stress moments and hence would yield a more economical design.
  2. For frames subjected to intense horizontally distributed load (frame 3) there is need to consider axial deformation if  $I_2/I_1 > 1$  or  $h/L <$
- 0.3. Under these conditions the contribution of axial deformation to the internal stresses becomes very significant.

**References:**

- Ghali A, Neville A. M.(1996) *Structural Analysis: A Unified Classical and Matrix Approach*. 3<sup>rd</sup> Edition. Chapman & Hall London
- Graham R, Alan P.,(2007). *Single Storey Buildings: Steel Designer's Manual* Sixth Edition, Blackwell Science Ltd, United Kingdom
- Hibbeler, R. C.(2006). *Structural Analysis*. Sixth Edition, Pearson Prentice Hall, New Jersey
- Nash, W.,(1998). *Schaum's Outline of Theory and Problems of Strength of Materials*. Fourth Edition, McGraw-Hill Companies, New York
- Reynolds, C. E.,Steedman J. C. (2001). *Reinforced Concrete Designer's Handbook*, 10<sup>th</sup> Edition) E&FN Spon, Taylor & Francis Group, London
- Saikat, B., (2001). *Tips and Tricks for Computer-Aided Structural Analysis*, Ensel Software, India
- Samuelsson A., Zienkiewi cz O. C.(2006), Review: History of the Stiffness Method. *International Journal for Numerical Methods in Engineering*. Vol. 67: 149 – 157

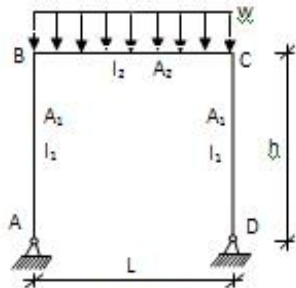

Figure 2

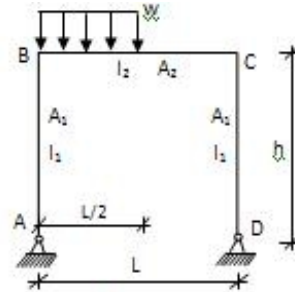
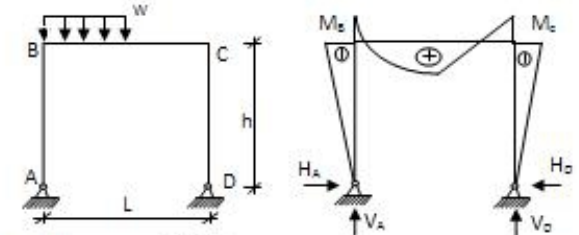
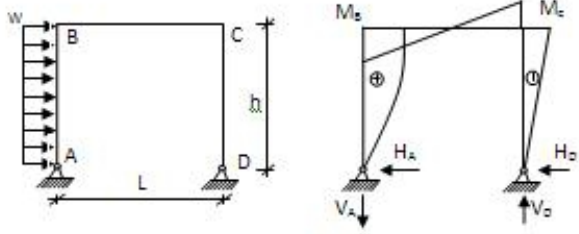

Figure 3

Table 1: Internal stresses for a loaded rigid frame

|          | <p> <math>A_1</math> = Cross-sectional area of the columns<br/> <math>I_1</math> = Second moment of area of the column cross-section<br/> <math>A_2</math> = Cross-sectional area of the beam<br/> <math>I_2</math> = Second moment of area of the beam cross-section         </p> $s_1 = \frac{12I_1}{h^2 A_1} \quad s_2 = \frac{12I_2}{L^2 A_2}$ $\beta = \frac{s_2}{s_1}$ |
|----------|--|
| Frame No | LOADED FRAME   |
| 1        | <p> <math display="block">M_B = M_C = \frac{w h^2 I_1 I_2}{8 h^2 I_1 + 12 h^2 I_2 + 2 s_1^2 I_1}</math> <math display="block">V_A = V_D = \frac{w L}{2} \quad H_A = H_D = \frac{w h I_1 I_2}{8 h^2 I_1 + 12 h I_2 + 2 s_1^2 I_1}</math> </p>   |

|          |  |
|----------|--|
| <p>2</p> |  $M_B = M_C = \frac{wh^2 l^2 I_2}{2(wh^2 I_1 + 12h^2 I_2 + 24l^2 I_3)}$ $V_A = \frac{2wl}{3} \quad V_D = \frac{wl}{3}$ $H_A = H_D = \frac{whl^2 I_2}{2(wh^2 I_1 + 12h^2 I_2 + 24l^2 I_3)}$  |
| <p>3</p> |  $M_C = -\frac{wh^2 (2hI_2 + 6lI_3)}{2(wh^2 I_1 + 12h^2 I_2 + 24l^2 I_3)}$ $M_B = \frac{wh^2 (2h^2 I_2 + 6h^2 I_3 + 24l^2 I_3)}{2(wh^2 I_1 + 12h^2 I_2 + 24l^2 I_3)}$ $V_A = V_D = \frac{wh^2}{2l}$ $H_D = \frac{wh^2 (2hI_2 + 6lI_3)}{2(wh^2 I_1 + 12h^2 I_2 + 24l^2 I_3)} \quad H_A = wh - H_D$ |

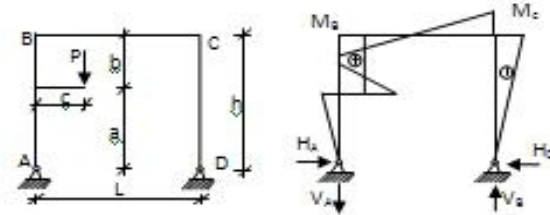
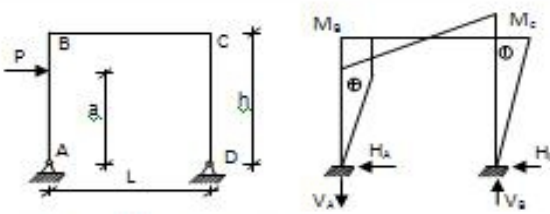
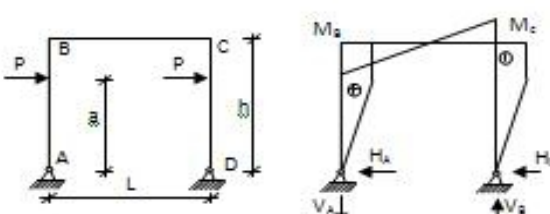

|          |  |
|----------|--|
| <p>4</p> |  $M_C = -\frac{6Pc h [b I_2 (h+a) + h I_1]}{6 h^3 I_2 + 12 h^2 I_1 + 6 c^2 I_2}$ $V_A = \frac{P(h-c)}{h}$ $H_A = H_D = \frac{6Pc [b I_2 (h+a) + h I_1]}{6 h^3 I_2 + 12 h^2 I_1 + 6 c^2 I_2}$ $M_D = P c \left( 1 - \frac{6h [b I_2 (h+a) + h I_1]}{6 h^3 I_2 + 12 h^2 I_1 + 6 c^2 I_2} \right)$ $V_D = \frac{Pc}{h}$                                      |
| <p>5</p> |  $M_D = P a \left[ 1 - \frac{2h [2b I_2 (h-a) + 2a^2 I_2 + 2h I_1]}{6 h^3 I_2 + 12 h^2 I_1 + 6 a^2 I_2} \right]$ $M_C = -\frac{2P a h [2b I_2 (h-a) + 2a^2 I_2 + 2h I_1]}{6 h^3 I_2 + 12 h^2 I_1 + 6 a^2 I_2}$ $V_A = V_D = \frac{P a}{h}$ $H_D = \frac{2P a [2b I_2 (h-a) + 2a^2 I_2 + 2h I_1]}{6 h^3 I_2 + 12 h^2 I_1 + 6 a^2 I_2} \quad H_A = P - H_D$ |
| <p>6</p> |   |

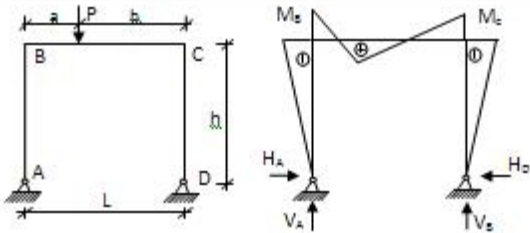
|   |   |
|---|---|
|   | $M_B = P \left[ (h + a) - \frac{h^2(4h^2 - ah^2 + 2a^2h - a^3)I_2 + 12h^2 I_1 + 2a^2 I_2}{2h^2 I_2 + 12h^2 I_1 + 2a^2 I_2} \right]$ $M_C = P \left[ (h - a) - \frac{h^2(4h^2 - ah^2 + 2a^2h - a^3)I_2 + 12h^2 I_1 + 2a^2 I_2}{2h^2 I_2 + 12h^2 I_1 + 2a^2 I_2} \right]$ $V_A = V_D = \frac{2Pa}{L}$ $H_D = \frac{P \left[ (4h^2 - ah^2 + 2a^2h - a^3)I_2 + 12h^2 I_1 + 2a^2 I_2 \right]}{2h^2 I_2 + 12h^2 I_1 + 2a^2 I_2} \quad H_A = 2P - H_D$ |
| 7 |  $M_B = M_C = -\frac{6Pab h^2 I_2}{2h^2 I_2 + 12h^2 I_1 + 2a^2 I_2}$ $V_D = \frac{Pa}{L} \quad V_A = P - V_D$ $H_A = H_D = \frac{6Pab h I_2}{2h^2 I_2 + 12h^2 I_1 + 2a^2 I_2}$   |

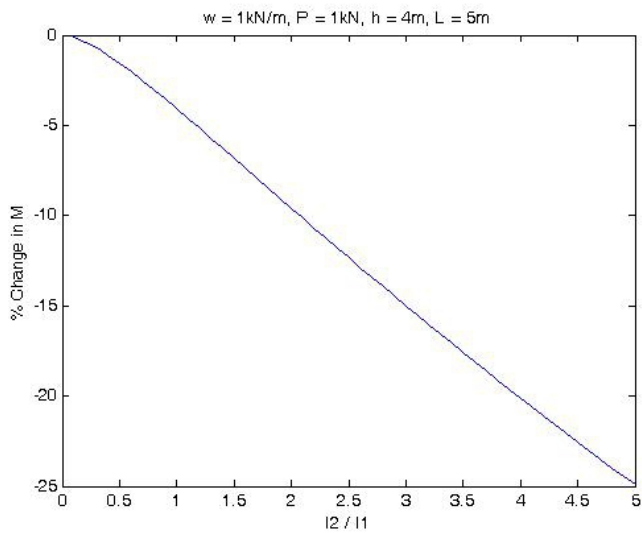

Figure 4: A plot of the percentage (%) change in internal stresses of frames 1, 2 and 7 versus the ratio of beam second moment of area to column moment of area

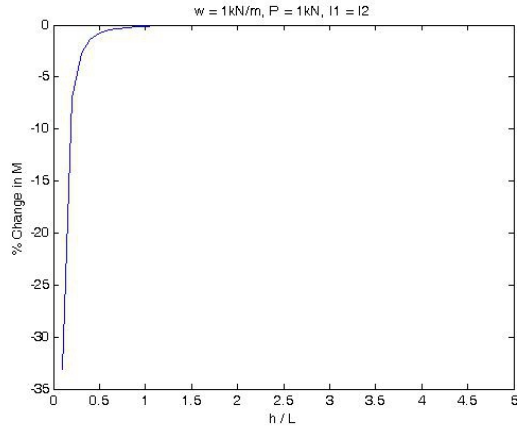

Figure 5: A plot of the percentage (%) change in internal stresses of frames 1, 2 and 7 versus the ratio of height to length of portal frame

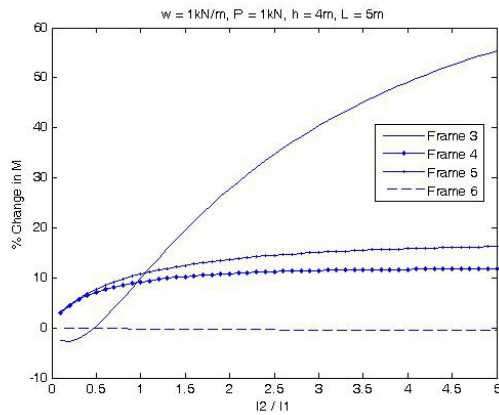

Figure 6: A plot of the percentage (%) change in internal stresses of frames 3,4,5 and 6 versus the ratio of beam second moment of area to column second moment of area

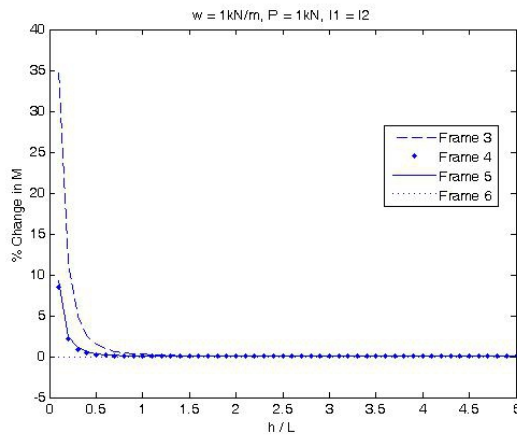

Figure 7: A plot of the percentage (%) change in internal stresses of frames 3,4,5 and 6 versus the ratio of height to length of portal frame