

# **SIMULATION AND MODELING THE DEFERRED BEHAVIOR INDUCED BY THE CREEP OF A REINFORCED CONCRETE SECTION**

***C. Oubraham***

Tizi Ouzou University (UMMTO), Tizi Ouzou, Algeria Research Unit:  
Materials, Processes and Environment (UR/MPE), Boumerdes University  
Boumerdes, Algeria

***S. Drizi***

Tizi Ouzou University (UMMTO), Tizi Ouzou, Algeria

***B. Safi***

***A. Benmounah***

Research Unit: Materials, Processes and Environment (UR/MPE),  
Boumerdes University Boumerdes, Algeria

---

## **Abstract**

In the reinforced concrete structures, the differed deformations due to creep increase with time. They become dominating compared to the instantaneous strains, corresponding to a given loading. In order to ensure itself of the good behavior of an element or a concrete structure reinforced in service and with the absolute limit, it is necessary to correctly evaluate the instantaneous and differed deformations and displacements. Within the framework of this study one is interested in modeling and simulation of the behaviors instantaneous and differed from a zone bent out of reinforced concrete. For the simulation of the instantaneous behavior, in composed inflection, an existing program is used and of the complements of validations is realized. For the modeling of the differed behavior, a formulation based on the method of the adjusted effective module is presented. Another data-processing program is developed. It makes it possible to simulate the deformations of a zone bent under loading supported in time. The differed effects are taken into account by using the coefficient of creep recommended by the CEB 90. The simulations carried out on experimental tests allow the validation of the approach used. The results show that the best functioning of the approach used by the program and the comparison test-calculation is satisfactory.

---

**Keywords:** Nonlinear modeling, creep, instantaneous behavior, deferred behavior, section, inflection, reinforced concrete.

## **Introduction**

In order to ensure itself of the good behavior of an element or a concrete structure reinforced in service and with the absolute limit, it is necessary to correctly evaluate the instantaneous and differed deformations and displacements. All studies whether experimental or theoretical those exist in literature, are referring to the failure behavior of the reinforced elements concrete. However, research continues to develop the modeling on their long term behavior. Several researchers have developed a particularly important aspect by using the modeling of the deferred behavior of reinforced elements (Savoia, 2002; Savoia, 2003; Ascione, 2006a; Ascione, 2006b; Berardi, 2003). More recently, citing as an example, Lugui et al have developed a mechanical model of the beams in fibre-reinforced polymer (FRP) materials systems (Ascione, 2011). Theses authors were studied a long-term behavior of this elements beams plated in extern with prestressed FRP systems. Author studies were carried on the rheological behavior of fibre-reinforced polymer materials (FRP), in order to characterize their viscous properties [Savoia, 2002; Berardi, 2003; Choi, 2007].

With regard to the creep of a section reinforced elements concrete, works continues on the modeling of deferred behavior of a section reinforced concrete. Within the framework of this study one is interested in modeling and simulation of behaviors instantaneous and deferred from to creep from a zone bent out of reinforced concrete. One presents, initially, a formulation for the modeling of the instantaneous nonlinear behavior, until rupture, of a reinforced concrete section subjected to the inflection made up. Then, an approach is proposed making it possible to model the evolution of the instantaneous and differed strains, under loading maintained in the course of time, by taking account of creep. This approach is based on the method of the adjusted effective module (Diab, 2008; Bazant, 1972; Bazant, 1988). A computational tool is elaborate making it possible to simulate the evolution of the deformations of the concrete section reinforced under loading of inflection maintained constant in the course of time.

## **2. Base model**

The average behavior of a bent zone of a reinforced concrete element is modeled by studying the balance of a reinforced concrete cross section subjected to the made up inflection. The following design assumptions are admitted:

- Cross-bending of a section in average plan, charged in its plan and symmetry (figure 1).

- Conservation of the plane section after deformation (assumption of Bernoulli).
- Perfect Adherence enters the concrete and the reinforcements.

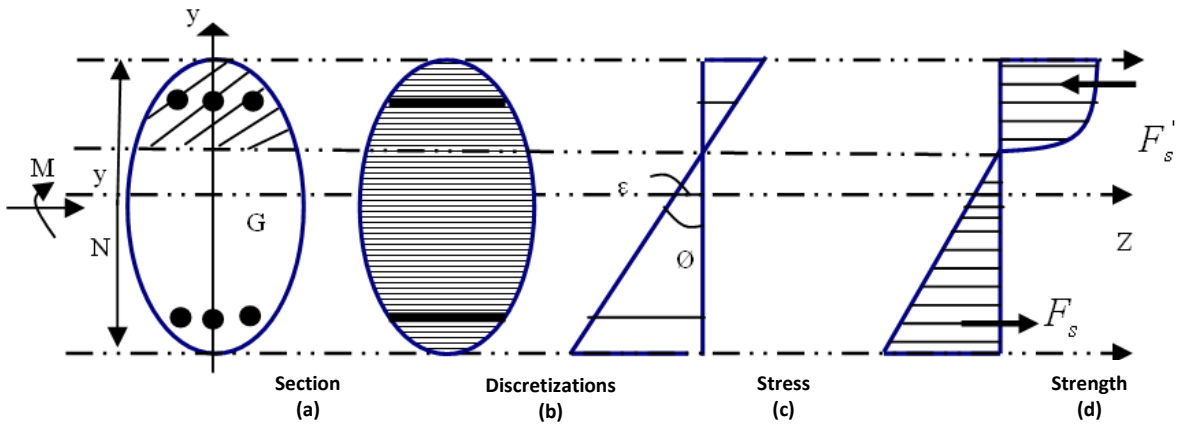

**Figure 1:** the section modeling

Consider the section under one bending moment  $M$  and a normal effort  $NR$  acting in the geometrical center  $G$  of the section. The longitudinal deflections in the section are defined using two parameters: the deformation  $\varepsilon_g$  on the level of the geometrical center  $G$  and curve  $\varphi$ . The longitudinal deflection  $\varepsilon(y)$  of a horizontal fiber located at the ordinate  $y$  compared to the axis  $Gz$  is given by:

$$\varepsilon(y) = \varepsilon_g + \varphi \cdot y \quad (1)$$

The efforts balanced by the section are given by:

$$N = \int_S \sigma(y) ds \quad \text{and} \quad M = \int_S \sigma(y) y ds \quad (2)$$

By using the elastic modulus of materials, a relation between the efforts and the deformations in the section:

$$\begin{Bmatrix} N \\ M \end{Bmatrix} = \begin{bmatrix} \overline{EA} & \overline{ES} \\ \overline{ES} & \overline{EI} \end{bmatrix} \begin{Bmatrix} \varepsilon_g \\ \varphi \end{Bmatrix} = [K_s] \begin{Bmatrix} \varepsilon_g \\ \varphi \end{Bmatrix} \quad (3)$$

Conversely the relation (3) is written:

$$\begin{Bmatrix} \varepsilon_g \\ \varphi \end{Bmatrix} = [K^{-1}] \begin{Bmatrix} N \\ M \end{Bmatrix} \quad [KS] \text{ is the rigidity of the section.}$$

Under the efforts  $N$  and  $M$ , the deformations  $\varepsilon_g$  and  $\varphi$  are given by using a nonlinear iterative calculation. The components of the rigidity of matrix  $[KS]$  are given in the section (figure 1) out of horizontal fibers (nb) and steels beds (na).

$$\begin{aligned} \overline{EA} &= \int_S E_S .dS = \sum_{i=1}^{nb} E_{bi} \Delta S_{bi} + \sum_{j=1}^{na} E_{aj} A_{aj} \\ \overline{ES} &= \int_S E_S .y .dS = \sum_{i=1}^{nb} E_{bi} .y_{bi} .\Delta S_{bi} + \sum_{j=1}^{na} E_{aj} .y_{aj} .A_{aj} \\ \overline{EI} &= \int_S E_S .y^2 .dS = \sum_{i=1}^{nb} E_{bi} .y_{bi}^2 .\Delta S_{bi} + \sum_{j=1}^{na} E_{aj} .y_{aj}^2 .A_{aj} \end{aligned} \quad (5)$$

### 3. Modeling of the instantaneous behavior of the materials

#### 3.1 Concrete modeling in compression

In general, the behavior of the compressed concrete is described by the law Sargin (Sargin, 1971).

BPEL 83.

$$\frac{\sigma_b}{f_{bc}} = \frac{k \cdot \left(\frac{\varepsilon_b}{\varepsilon_{b0}}\right) + (k' - 1) \cdot \left(\frac{\varepsilon_b}{\varepsilon_{b0}}\right)^2}{1 + (k - 2) \cdot \left(\frac{\varepsilon_0}{\varepsilon_{b0}}\right) + k' \cdot \left(\frac{\varepsilon_b}{\varepsilon_{b0}}\right)^2} \quad (6)$$

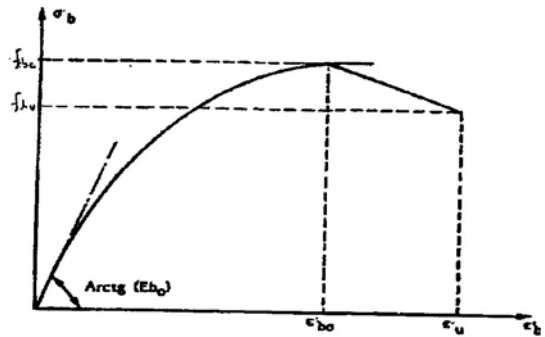

Figure 2: Model of Sargin (Sargin, 1971)

With:

$f_{bc}$  : Compressive strength of the concrete,

$\varepsilon_{b0}$  : Deformation of peak corresponding to,

$K$  and  $K'$  : Parameters of the model.

#### 3.2 modeling of the concrete in tensile

The formulation of Grelat (Grelat, 1978) consists in allotting a fictitious triangular distribution of the stress in the tended zone of the cross section (figure 3). Beyond the peak the concrete stress on the level of the most tended reinforcement decrease parabolic ally until being cancelled completely when the reinforcement is plasticized. This supposes that the contribution of the concrete tended between the cracks disappears after plasticization from steels. This model is expressed as follows (Grelat, 1978):

Before cracking:  $\sigma_t = E_{b0} . \varepsilon_t$  after cracking:  $\sigma_t = f_{ij} \left( \frac{\varepsilon_y - \varepsilon_i}{\varepsilon_y - \varepsilon_{ct}} \right)^2 \quad (7)$

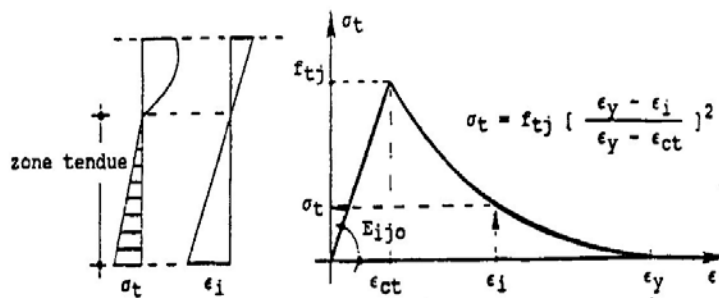

Figure 3: Grelat Model (Grelat, 1978)

With:

$\epsilon_i$  : Concrete deformation on the level of the most tended reinforcement

$\sigma_i$  : the stress concrete on the level of the most tended reinforcement

$\epsilon_y$  : Deformation corresponding to the plasticization of steels.

### 3.3 modeling of the steel behavior

Using the elasto-plastic model,

$$\sigma_s = E_a \epsilon \text{ if } \epsilon \leq f_e / E_a$$

$$\sigma_s = f_e \text{ if } \epsilon > f_e / E_a \quad (8)$$

### 4. Modeling of the behavior differed

Under a load applied to one moment to a concrete element, the total deflection at the moment t is given by:

$$\epsilon(t, t_0) = \epsilon_i(t_0) + \epsilon_{fi}(t, t_0) + \epsilon_r(t, t_0) \quad (9)$$

In the following, consider the deferred deformations due to creep by admitting a viscoelastic behavior for the concrete and by using the principle of BOLTZMANN superposition. For this, one can write (Bazant, 1980):

$$d(\epsilon_i(t_0) + \epsilon_{fi}(t, t_0)) = J(t, t_0) d\sigma \quad (10)$$

Where J (T, t0) is the creep function given by,

$$J(t, t_0) = \frac{1}{E_b(t_0)} [1 + \varphi(t, t_0)] ; \text{ With } \varphi(t, t_0) \text{ is the creep coefficient.} \quad (11)$$

The stain (deformation) obtained starting from a variable of stress-strain is expressed by the integral:

$$\epsilon_i(t_0) + \epsilon_{fi}(t, t_0) = \int_{t_0}^t J(t, \tau) \frac{\partial \sigma}{\partial \tau} d\tau \quad (12)$$

Where  $\tau$  is an independent variable ranging between  $t_0$  and t.

The integral resolution (12) is hard and requires the storage of all the history of loading on the level of each fiber of the studied section. To simplify the resolution, the method of the adjusted effective module is used.

$$\varepsilon_i(t_0) + \varepsilon_{fl}(t, t_0) = \frac{\sigma(t)}{E_b^*(t, t_0)} \quad (13) \quad \text{Where}$$

$$E_b^*(t, t_0) = \frac{E_b(t_0)}{1 + \chi(t, t_0)\phi(t, t_0)} \quad (14)$$

In the creep case, the behavior of the studied section is done by replacing the instantaneous module  $E_b(t_0)$  by the adjusted effective module  $E_b^*(t, t_0)$ .

$\chi(t, t_0)$  is the coefficient of ageing. It makes it possible to take account of a certain variation of the constraints in time. In the present study, the coefficients  $\chi(t, t_0)$  and  $\phi(t, t_0)$  are calculated according to code CEB 90 (CEB-FIP, 1990).

### 5. Method of resolution nonlinear

In nonlinear elasticity, the efforts (N, M) developed in the section for deformations  $(\varepsilon_g, \varphi)$ , can be calculated. The strain determination from the efforts is not possible by a direct method. In this case, the use of an iterative method of calculation can be considered. Initially, one considers the state of balance of the section under low values of the efforts (N, M) and the calculations can be carried out by considering a linear elastic behavior. Under an increment  $(\Delta N, \Delta M)$  of the efforts, the increase in the deformations  $(\Delta \varepsilon_g, \Delta \varphi)$  in the section is sought by the method of successive substitutions using the rigidity of matrix. The flow chart of nonlinear section resolution is presented in figure 4. To allow the study and the analysis of the behavior instantaneous or differed from an unspecified reinforced concrete section, subjected to the composed inflection, two data-processing programs were developed:

- Program SECTNOL (analyzes of a Section into Non-linear until rupture) allows the simulation of the instantaneous behavior, until the rupture, of an unspecified reinforced concrete section subjected to the made up inflection. It makes it possible to carry out calculation  $(M - \varphi)$ : The section is subjected to a normal load NR fixed and one bending moment M growing until the rupture.

- Program SECTFLU (calculation of a concrete Section reinforced with respect to Creep) allows to simulate the evaluation in the time of the curve of the studied section subjected to one bending moment M constant.



## 6. Applications

### 6.1 Example of simulation of the instantaneous behavior of beam OG3 (Foure, 1985)

One is interested in the evolution of the bending moment according to the curve, for a fixed normal effort. It is about a reinforced concrete beam, provided with a moderate percentage of reinforcements (1, 2%), so that the rupture is reached initially by plasticization of steels. The cross section is rectangular armed doubling, subjected to the pure bending. (Figure 5)

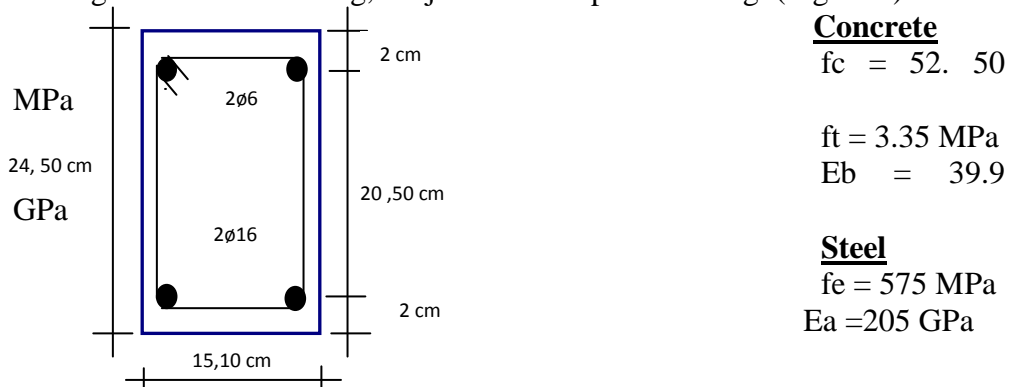

Figure 5: Geometrical and the material characteristics of the beam (Foure, 1985)

The numerical results are represented graphically in figure 6. It is noted that the behavior of beam OG3 is well approached by calculation in this study. Simulation shows a good estimate of moment and also of the corresponding maximum curve.

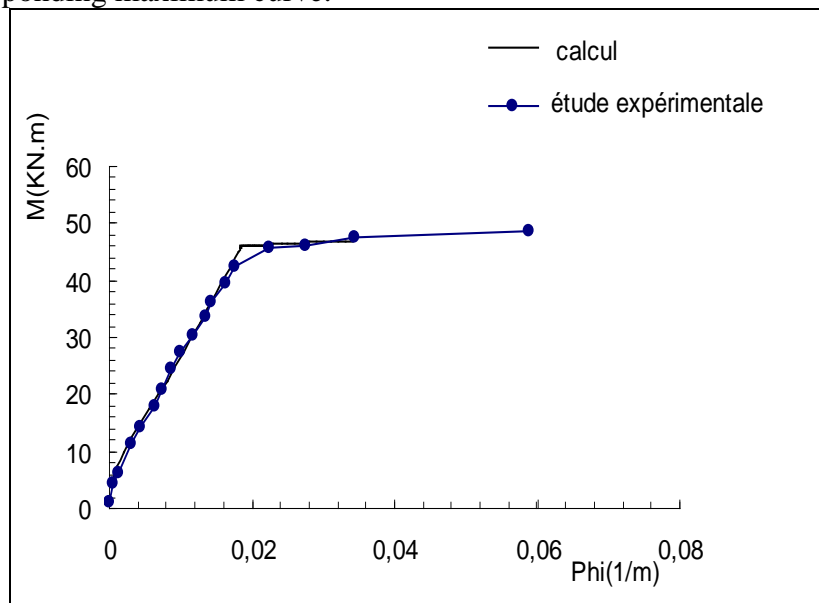

Figure 6: Representation of the curve Moment - curve



## 6.2 Example of simulation of the behavior differed curve times

### 6.2.1 Example from test of Tanimura (Tanimura, 2005)

It acts of a concrete beam reinforced high performance (BHP), the cross section rectangular is subjected to the inflection of 4 points, under loading of long duration corresponding to one moment constant  $M=15\text{KN}$  (figure 7). The numerical results are represented graphically in figure 8.

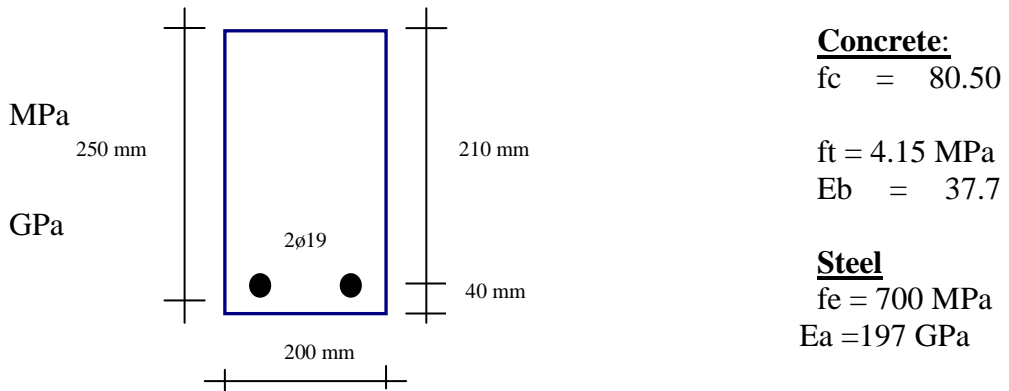

**Figure 7:** Geometrical and the material characteristics of the beam (Tanimura, 2005)

It is noted that the behavior of the beam is well approached by the calculation carried out in this study. Simulation shows a good estimate of the maximum curve and also of corresponding time.

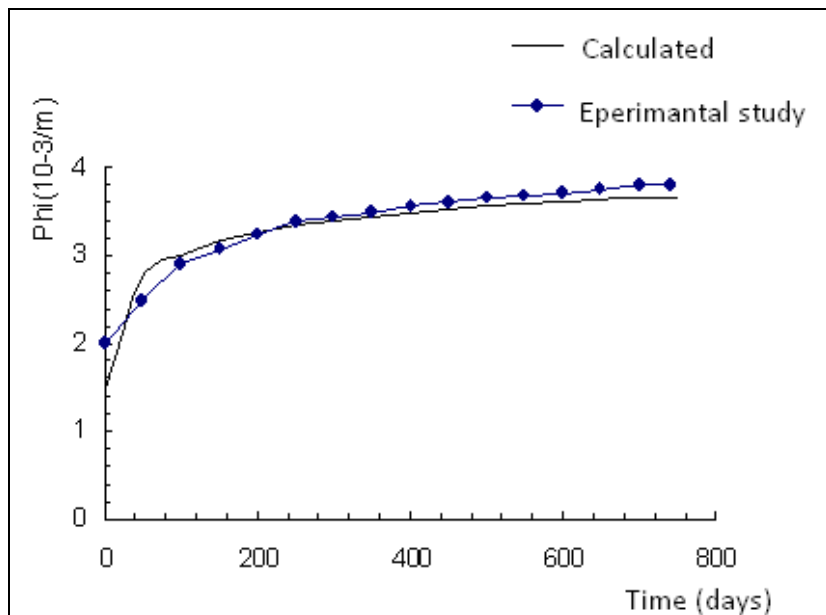

**Figure 8:** The curve-times representation

### 6.2.2 Example of HALL test (Stephanie Hall, 2000)

It acts of a reinforced concrete beam, the cross section rectangular is subjected to inflection 4 points, under loading of long duration corresponding to one moment constant  $M=10,5KN$  (figure 9). The numerical results are represented graphically in figure 10.

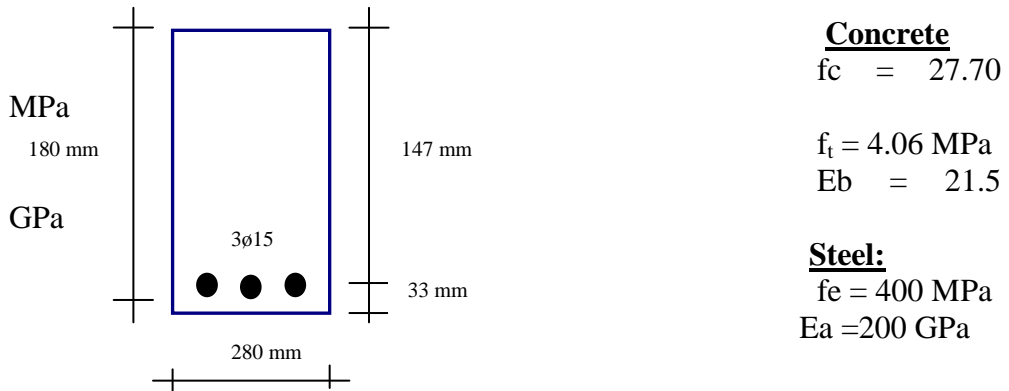

**Figure 9:** Geometrical and the material characteristics of the beam (Stephanie Hall, 2000)

For this test, the experimental behavior of the beam is well simulated by calculation, until  $t = 150$  days and with beyond the variation becomes considerable.

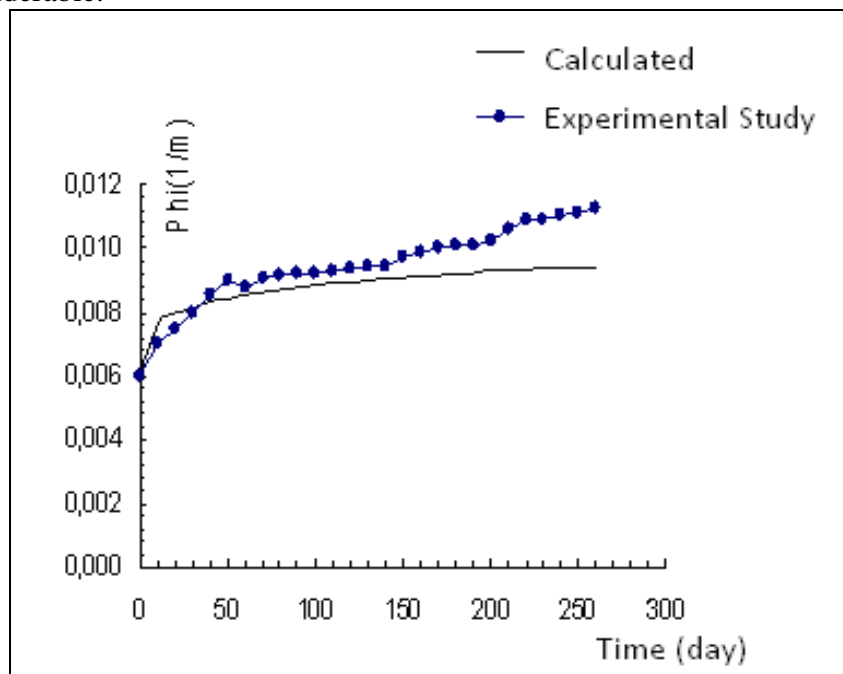

**Figure 10:** The curve-times representation

## 7. Conclusions

Within the framework of this study, one was interested in the modeling and the simulation of the behaviors instantaneous and differed from one bent out of reinforced concrete. First of all, a formulation is presented for the modeling of the nonlinear instantaneous behavior of an unspecified reinforced concrete section, bent under monotonous loading until the rupture. An existing calculation program is used, making it possible to validate the formulation presented. One was interested then in modeling of the differed behavior, which had with creep, of the section bent under loading supported in time. To take account of the differed deformations which had with creep, one uses a formulation based on the method of the adjusted effective module. The creep coefficient used is given according to the model of the CEB90. The behavior differed from the section is studied while following the evolution of the curve according to time under constant loading. For the needs for calculation, a second program is put in point. The validation is carried out by considering several experimental examples extracted the literature. The comparison test-calculation is satisfactory and shows the correct operation of the approach used.

## References:

- M. Savoia, D. Ferretti, C. Mazzotti. Creep behavior of RC tensile elements retrofitted by FRP plates. ICCI '02 Conference Proceedings, San Francisco (2002).
- M. Savoia, B. Ferracuti, C. Mazzotti. Creep deformation of FRP-plated R/C tensile elements using solidification theory. *Comp. Modelling of Concrete Structures – EURO-C, Austria* (2003).
- Ascione F., Mancusi, G. Long-term behavior of CFRP laminates: an experimental study. CICE Conference (2006).
- Ascione, F., Berardi, V.P., Feo, L., Giordano, A. On the creep behavior of CFRP pultruded laminates: an experimental study. The Second fib Congress, Naples (2006).
- Berardi, V.P., Di Nardo, E., Giordano, A. On the creep behavior of reinforced concrete beams strengthened with FRP: a numerical investigation. II Composite in Construction International Conference CCC2003, Rende (CS), Italy (2003).
- Ascione L., Berardi V.P., Aponte A., Long-term behavior of PC beams externally plated with prestressed FRP systems: A mechanical model, *Composites Part B: Engineering*, Vol. 42, 5, 2011, Pages 1196–1201
- Savoia M, Ferretti D, Mazzotti C. Creep behavior of RC tensile elements retrofitted by FRP plates. In: ICCI '02 conference proceedings, San Francisco, USA; 2002.

- Choi K.K, M. Pania, R.Taha, Mahmoud M. Shear creep of epoxy at the concrete-FRP interfaces. *Compos Part B: Eng* 2007; 38(5–6):772–80.
- Diab H, Wu Z. A linear viscoelastic model for interfacial long-term behavior of FRP–concrete interface. *Compos Part B: Eng* 2008;39(4):722–30.
- Z.P. Bazant. Prediction of concrete creep effects using age – adjusted effective modulus method, *ACI Journal*, 69(4), pp212 – 217, 1972.
- Z.P. Bazant. Mathematical models for creep and shrinkage in concrete structures. *Creep and shrinkage in concrete structures*, John Wiley & Sons limited, pp163 – 255, Chichester, 1988.
- M. Sargin. Stress-strain relations for concrete and the analysis of the structural concrete sections. S.M. Study n°4, Solid Mechanics Division, University of Waterloo, Canada, 1971.
- A. Grelat. Comportement non linéaire et stabilité des ossatures en béton armé. *Annales de L’ITBTP*, Novembre 1978.
- Z.P. Bazant and F.H. Wittman., *Creep and shrinkage in concrete structures*. Wiley, New York, 1980.
- Comité Euro – International du Béton, Fédération International de la Précontrainte (CEB-FIP), paris, France, 1990.
- B.Foure. Béton à haute résistance – Rapport sur les essais de poteaux et poutre (OG). contrat SETRA-CEBTP 84-40-020, rapport interne, Novembre 1985.
- M. Tanimura, M.Suzuki, I. Marutyama, and R. Sato. Improvement of Time-Dependent Flexural Behavior in RC Members by Using Low Shrinkage-High-Strength Concrete. *ACI SP-228, Proc. of 7 th international symposium on the utilization of high- strength/high-performance concrete*, 1373-1396, 2005.
- T. Stephanie Hall. Deflections of Concrete Members Reinforced with Fibre Reinforced Polymer (FRP) Bars. Master of Science, department of civil engineering, Calgary, Alberta, January 2000.