

# **OBSERVATION AND MITIGATION OF POWER TRANSIENTS IN 160GBPS OPTICAL BACKHAUL NETWORKS**

*Vikrant Sharma*

*Anurag Sharma*

Electronics and Communication Engg., CT Group of Institutions

*Dalveer Kaur*

Punjab Technical University, Jalandhar, India

---

## **Abstract**

Erbium doped fiber amplifiers (EDFA) are most commonly used in optical networks for the most assorted applications. In this paper we have investigated the power transient effect of the cascaded erbium-doped fiber amplifiers (EDFA) in dense wavelength optical ring networks. The result shows, the power transient effect of EDFAs when channels are changed due to failure or channel reconfiguration. And also ring laser configuration technique has been reported to mitigate the effect of power transients.

---

**Keywords:** DWDM, EDFA, OADM, OXC, power transients

## **Introduction**

Wavelength routed optical networking can achieve transmissions, routing, switching, and protections of high-speed information streams in the optical domain by the optical add/drop multiplexers (OADM) and the optical cross-connects (OXC). Optical networking is ideally positioned to meet the demand for explosive communication capacity. Nowadays, the erbium-doped fiber amplifiers (EDFA) are widely used in such networks for the purpose of transparent loss compensation without O/E conversion. These EDFAs are typically operated in the gain-saturation regime to guarantee maximum channel signal-to-noise ratio. However, the number of the wavelength-multiplexed channels traversing a single EDFA may vary as a result of the network reconfiguration, the network protection, and the network growth. In these reconfiguration and protection applications, the optical network switching time is required in the order of millisecond, which is around to the spontaneous lifetime of the Er upper level. Consequently, the power variation of EDFA input will lead to undesirable fast power transients in the surviving channels by dynamic cross-gain saturation effect. [3] In an optical implementation with ring laser configuration, the lasing power plays the reservoir of excited erbium-ions and swings in opposite direction to input signal variations. If sufficient lasing power is provided, optical power at the output of the EDFA is constant in time and lasing power can be propagated through the remaining amplifiers of the cascaded as compensating signal. All optical gain clamping ring laser method has been suggested in DWDM OADM ring network.

## **System design and simulation set-up**

The designed DWDM backhaul ring network architecture is based on a single unidirectional fiber ring topology having data rates of 10 Gbps. It consists of six OADM nodes as shown in fig. 1 connected by non linear single mode fiber. Each node is converting the electrical data into the optical signal and transmitting the optical link of DWDM ring.

Each node is also equipped with tunable transmitter operating in multiband environment and compound receiver with multiple filters; each receiver takes care of a particular data channel which owns a unique wavelength.

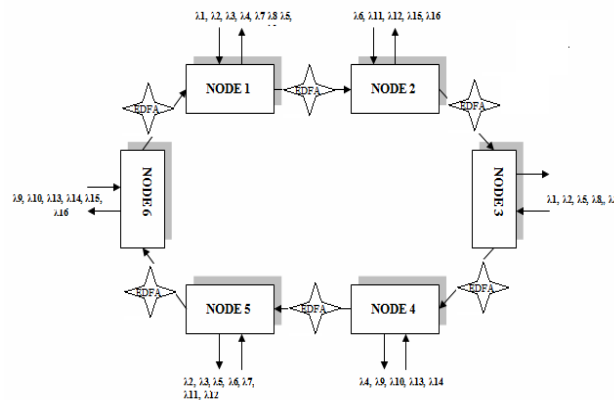

Fig. 1 six nodes, 16 channel DWDM OADM ring

Each node has the ability to add/drop any wavelength of each data channel. EDFA (erbium doped fiber amplifier) after each fiber span is inserted to compensate the fiber attenuation. LEAF fiber i.e. large effective area is used to compensate the nonlinearities of multichannel system. The power per channel of -9 dBm was used at transmitters. We used 16 wavelengths at 50 GHz (0.4nm) spacing ranging from 1550 to 1556 nm wavelength i.e. total bandwidth of 6 nm. Time delay block is used to connect signal from last node back to first node for performing ring simulation with multiple iterations.

The simulation setup for observing transients in optical ring network has been shown in fig. 2. For simplicity, only two wavelengths i.e. 1550 and 1556 nm is used for the observation of power transients. 1550nm wavelength is used as switching wavelength and 1556nm wavelength is used as surviving wavelength. Surviving wavelength is the wavelength, which excursion power transients when 1550nm wavelength is added or dropped. Rest other 14 wavelengths should be applied with null signal to make it inactive.

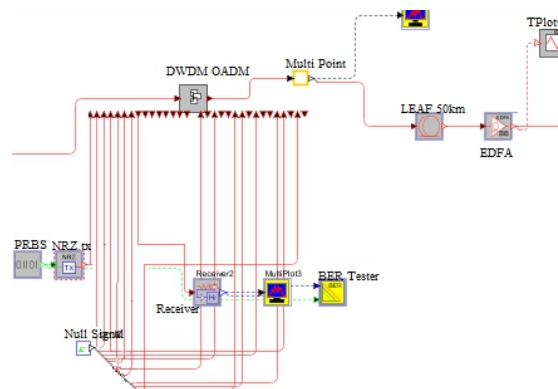

Fig. 2 Block diagram of simulation setup

The system is co-pumped at 980 nm with 55 mw of pump power and the Tx1 signal is at 1556 nm and TX2 is at 1550nm. After first EDFA transient plotter is attached to plot the transient effect. It must be noted that lambda 16 is the surviving channel and lambda 1 can be switched on and off with the help of switch. 1550nm channel is connected through switch so that it can be on off or add drop and 1556nm channel is directly attached and the third input is 980nm pump laser. Fig.3 shows practical simulation set up for observing transient. Figure

shows OADM first input is at 1550nm, which is to be added or dropped. Signals at 1556nm and 980nm are connected internally to OADM block

**Results and discussions**

It is observed from in Fig.4 the plot obtained at Tplotter in the schematic, the surviving signal power levels experience power excursions when some channels are dropped or added. This is due to the fact that when channels are added or dropped by network’s reconfiguration or failure, the power of the surviving channels decreases or increases due to cross saturation in the amplifiers. Power excursion of surviving channels can cause signal distortion by nonlinear effects or degradation of optical signal to noise ratio (OSNR).Two signals are plotted in the figure; one is 1550 nm and another is 1556 nm, It clear from the figure that when 1550nm signal is dropped at node 1, 1556nm signal produce transient and there is shoot in power level.

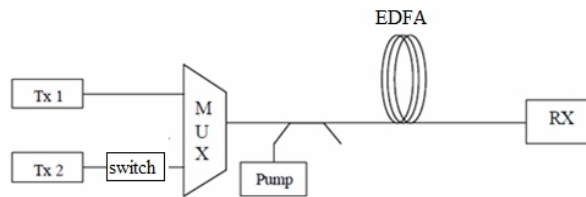

Fig. 3 Practical Simulation set up for transient observation

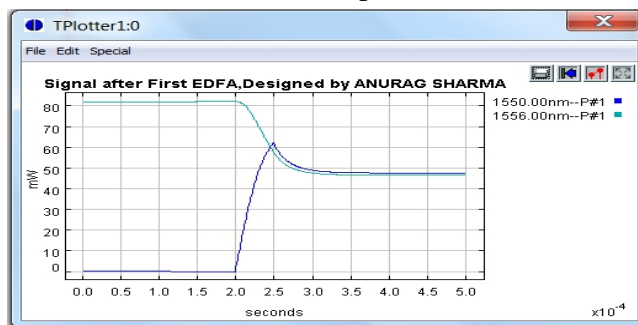

Fig. 4 Signal after first EDFA

Fig.5 shows the simulation setup for two node configuration i.e. after taking results from first EDFA at second node again 1550 nm channel is dropped and again we can see the effect on surviving channel. In this figure output from EDFA1 is connected to next OADM.

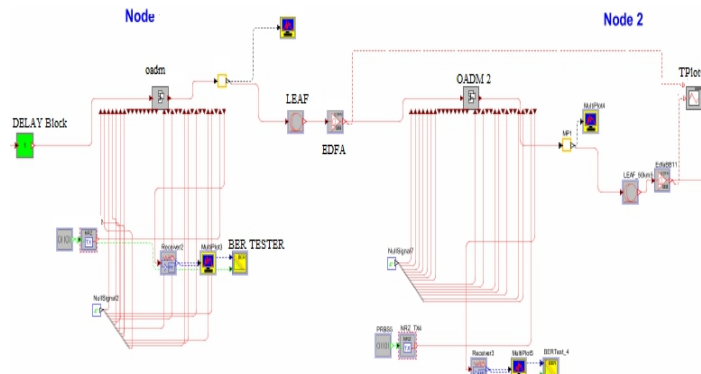

Fig.5 Simulation set up for 2 node configuration

Fig.6 shows the effect of transients after two EDFAs. It is observed that when at second OADM 1550nm signal is again dropped surviving channel i.e.1556nm signal again shoots up .The figure also shows that the power excursions experience faster rise times as the number of EDFAs in the chain increases.

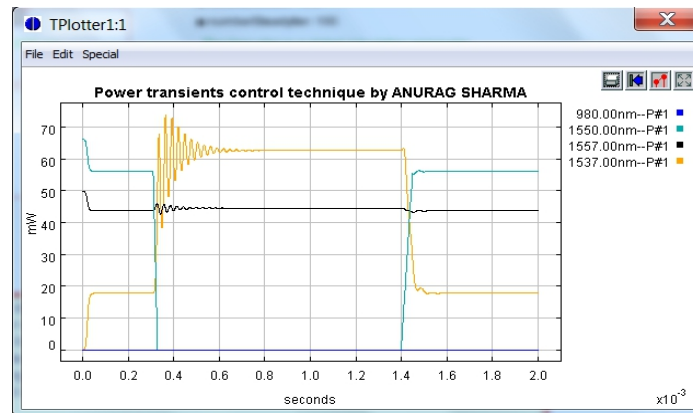

Fig. 6 Signals after second EDFA

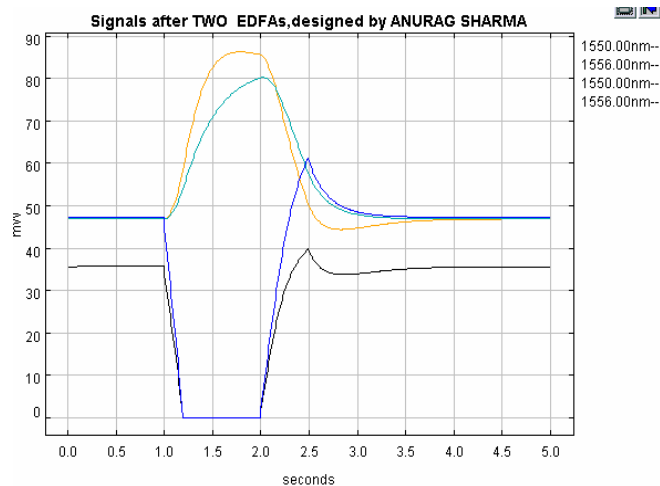

Fig.7 Ring laser configuration

Power excursions can be suppressed by using ring laser configuration. The schematic shown in Fig.7 uses a feedback loop to create a ring laser configuration. The EDFA provides the necessary gain. The signal at wavelength 1550 nm is turned on and off by the switch model shown in the schematic. The signal at wavelength 1556 nm is the surviving signal. The lasing signal at 1537 nm clamps the gain of the surviving channel when the signal at 1550 is dropped. The relaxation oscillations of the lasing signal at 1537 nm causes some relatively minor oscillations to be transformed to the surviving channel. However, these small power excursions are much smaller than those that would be realized without the gain control mechanism. The lasing signal evolves from the ASE noise of the EDFA. The lasing wavelength is selected by the filter in the feedback path. By controlling the amount of loss in the feedback path, we can trade gain stability for EDFA gain.

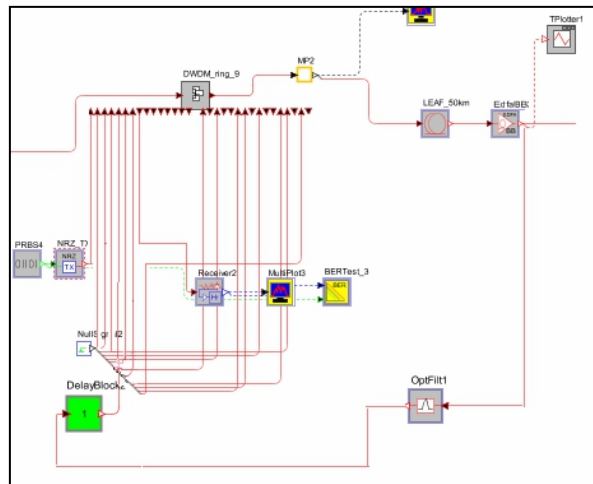

Fig 8: Power transient control technique

Fig. 8 shows power transient’s mitigation graph, It is clear from graph the transients are suppressed when ring laser technique is implemented.

**References:**

Marcio Freitas, Sidney Givigi Jr, Jackson Klein, ‘Transient control for cascaded EDFAs by using a multi- objective optimization approach, [www. mendeley.com/research/ transient-control-cascaded-edfas-using-multiobjective-optimization-approach](http://www.mendeley.com/research/transient-control-cascaded-edfas-using-multiobjective-optimization-approach), April 2004.

Dimitry Gorinevsky and Gennady Farbe, ‘System Analysis of Power Transients in Advanced WDM Networks, IEEE/OSA Journal of Light wave Technology, Vol. 22, No. 10,pp. 2245-2255, 2004.

Xiaodong TANG\* Qingji ZEN Yaohui JIN, and Yiping HAN,’ Performance Penalties due to Cascaded Erbium-Doped Fiber Amplifier Power Transients in Wavelength Routed Optical Networking, In Rare-Earth-Doped Materials and Devices IV, Shibin Jiang, Editor, Proceedings of SPIE Vol. 3942,2000

Soo-Jin Bae, Chang-Hee Lee,’ Transient Control of EDFA using Recirculating loop for WDM Transmission System, CLEO’2000, May 2005, CWK5.

Sorin Tibuleac and Mark Filer,’ Transmission Impairments in DWDM Networks With reconfigurable Optical Add-Drop Multiplexers, journal of light wave technology, vol. 28, and No. 4, FEBRUARY 15, 2010