

# **HEALTH INFORMATION SYSTEMS IN A DEVELOPING COUNTRY (CASE STUDY OF E-HEALTH SYSTEM IN A NIGERIAN HOSPITAL)**

*Umar Faruk Abubakar*

Faculty Of Science, Engineering And Computing  
School Of Computing And Information Systems, Kingston University London, England.

---

## **Abstract**

Health Information Systems (HIS) are one of the six essential and interrelated building blocks of a health system. A well-functioning HIS no doubt enhances accurate, timely and reliable information on health status and health care determinants required for and efficient and effective clinical and managerial decision making. In developing countries Application of HIS and e-health is in the increase. The analysis of Health Information systems in developing countries highlights areas of Challenges and areas needing Improvement.

---

**Keywords:** Health system, Nigeria

## **INTRODUCTION**

### **BACKGROUND OF THE PROBLEM**

The developing countries have a traditional method of Health care delivery with limited application of e-health. The e-health systems if strategically adopted will improve health care systems in a developing country like Nigeria. World health organization (WHO) stated the challenges facing human race in the 21<sup>st</sup> century is that of lack of access to qualitative care. The greater number of Nigerian population especially in low resource communities, have no access to qualitative care in terms of state of the art diagnostics facilities and technologies. The e- health if adopted and implemented can provide efficient and effective comprehensive health care services for the geographically dispersed people within both the urban and rural areas of the community.

Piette J.D et al (2012) highlighted the fact that difficulties in achieving the millennium development goals influence the innovation by planners to integrate health information systems and improve health and control cost.

### **AIM**

The aim of the study is to analyse the existing operations of the current health information system in Aminu Kano teaching Hospital (AKTH) identify the problems and to propose Improvement.

### **OBJECTIVES**

1. To conduct a literature survey of the Current health information systems,
2. To analyse the current situation of the case study and identify problems,
3. Propose a state of the art solution to address the problems in the HIS current system and model an improved HIS system
4. Evaluate the proposed system.

## **RESEARCH METHODOLOGY**

### **STUDY DESIGN**

The study is a prospective intervention study and will focus on Aminu Kano Teaching Hospital Nigeria. The hospital has the primary functions of treatment, teaching and research. The Implementation of current health information systems is to improve health care delivery across the hospital. Questionnaires were administered so as to obtain information necessary to permit analysis on the soft systems methodology and information on requirements of the current health information system. Interview will also be held Hague (1993) stated that the role of the interview is to derive accurate information.

The information obtained from the interview and the administered questionnaire are to enable the researcher obtain the requirements of the current situation on the operation of the system. The interview was conducted at the place of work which is consisted with the view point of Hammer and Champy (1994).The researcher will also apply observation in the process of data collection; NHS report (2001) support observation and informal discussion; because doctors, nurses, pharmacists hardly admit errors. Soft systems methodology (SSM) approach will be used to analyse the responses from the questionnaire administered, informal discussion and observations gained from the result will be used to evaluate the current system and identify problems leading to the development of solutions. Systems modelling are important because it is the interdisciplinary study of the use of models to conceptualize and construct systems.

### **LITERATURE REVIEW OF THE ART E-HEALTH SYSTEMS**

The draft report of the international telecommunication union (2008) described e-health as a generic term that refers to all digital health related information relevant to health care. Blaya et al (2010) described e-health as the use of information communication technologies (ICT) to support health and related field including health care services, health surveillance, health literature and health education knowledge and research. The World health organization( 2005)defined e-health as being the leveraging of the information and communication technology (ICT)to connect the provider ,patients and governments. E-Health system is defined by Althuwajiri (2008) as a patient care system that aid the transfer of information electronically and instantly.

### **TYPES OF HEALTH INFORMATION SYSTEMS CLINICAL INFORMATION SYSTEMS**

Clinical Information systems is based on technology and applied at the point of care. The system is designed based on the requirement and need for support and processing of information. The CIS systems provide storage with processing capabilities

### **COMMUNITY BASED HEALTH INFORMATION SYSTEMS**

Community health Information network (CHIN) may be conceived as a network that links health care stakeholders throughout a community, region or district. It also facilitate an efficient flow of funds information among various providers ,employers and other stake holders within a specified area(Chiu et al 2008,Puri et al 2009,Ro (Rodrigues J, 2010) .

### **E-PUBLIC HEALTH INFORMATION SYSTEMS**

The e- Public health information systems provide emerging e-technologies to support public health care and bring about improvement in the health care status. Araujo et al (2009) stated that community assessment for example involves in the process of collection, tabulation, analysis and communication of key health statistics

## **GEOGRAPHICAL INFORMATION SYSTEMS**

GIS technologies are useful in epidemiological and public health activities to mapping out certain endemic and epidemic disease among sub population across various regions, states or districts .The information collected will further be used to develop strategies for efficient and effective health care intervention.

## **HEALTH INFORMATION SYSTEMS TECHNOLOGIES IMAGING TECHNOLOGIES**

(Breu R. et al, February, 2009) Discusses that new technologies for health information systems (HIS) offer a transformed way of relationship and interaction among health care professionals

## **AGENT TECHNOLOGIES**

(Rodrigues J, 2010)cited (Nguyen et al 2009) and (Fonseca et al 2005)highlighting agent technology as being an emerging promising area of software development. Data mining technologies in Public health according to Kaur and Wasan (2006) obenshain (2004) and Silver et al (2009), (Rodrigues J, 2010) is applicable in the area of surveillance through automated surveillance system

## **E-HEALTH APPLICATIONS IN HEALTH CARE TELE-MEDICINE**

Telemedicine is defined as the use of video conferencing techniques to deliver consultation at a distance, (Coiera E, 2003)While (Sean Brennan, 2007)defined telemedicine as the use of electronic and information and communication technologies to provide and support health care where distance separates the participants.

## **SOFT SYSTEMS METHODOLOGY**

The Peter Check land's Soft Systems methodology (SSM) is an approach to tackling a messy real life situation. Gupta .A. and Ridhi .M.(2013)described SSM as an attempt to make an inquiry into real world situation, thereby providing a richer basis for understanding situation, it deals with the soft rather than the hard problems.

### Step 1 problem situation unstructured

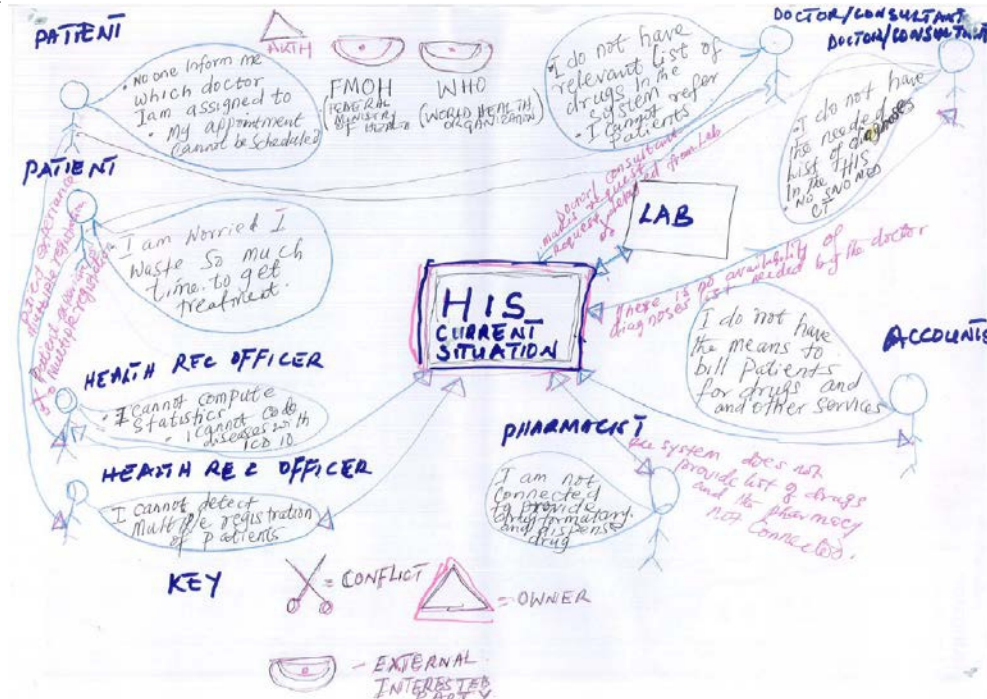

Figure1: RICH PICTURE OF CURRENT SITUATION

### STEP2 PROBLEMS APPRECIATION

Issues identified in the rich picture of the current HIS system and further provided the insight for the problems to be captured in the models for the proposed HIS

### STEP 3 ROOT DEFINITION

The root definition always ended in an acronym CATWOE .Root definition is also refer to as a problem definition in SSM. The concept of root definition is based on the expression do X by Y to achieve Z. The CATWOE i.e. employed to enrich the Root definition and the conceptual models (Bergvall .B., APRIL 2004). The root definition and the conceptual model are always being condensed statements about a system being investigated; it can be likened to a mission statement..

The PQR answer questions

P-what

Q-How to do it

R-Why we do it

P - Efficient and effective health Information management Systems

Q - Through health Information Systems analysis and design

R - So as to improve the current Health information management system in AKTH

Kano

- To improve patient care service delivery
- To reduce sufferings of patient
- To ease operational services
- To save lives

### CATWOE ANALYSIS

Therefore the researcher, employed CATWOE Analysis and root definition for a core description of a purposeful activity from a particular view point (Flood and Carson 1993 as cited by Suriya (2012)

### STEP 4: MODELING AND ARCHITECTURE DESIGN

The proposed modelling is towards designing integration and migration Strategy. In consistency with the methodology for this research UML was used throughout



USE CASE DIAGRAM BY THE AUTHOUR

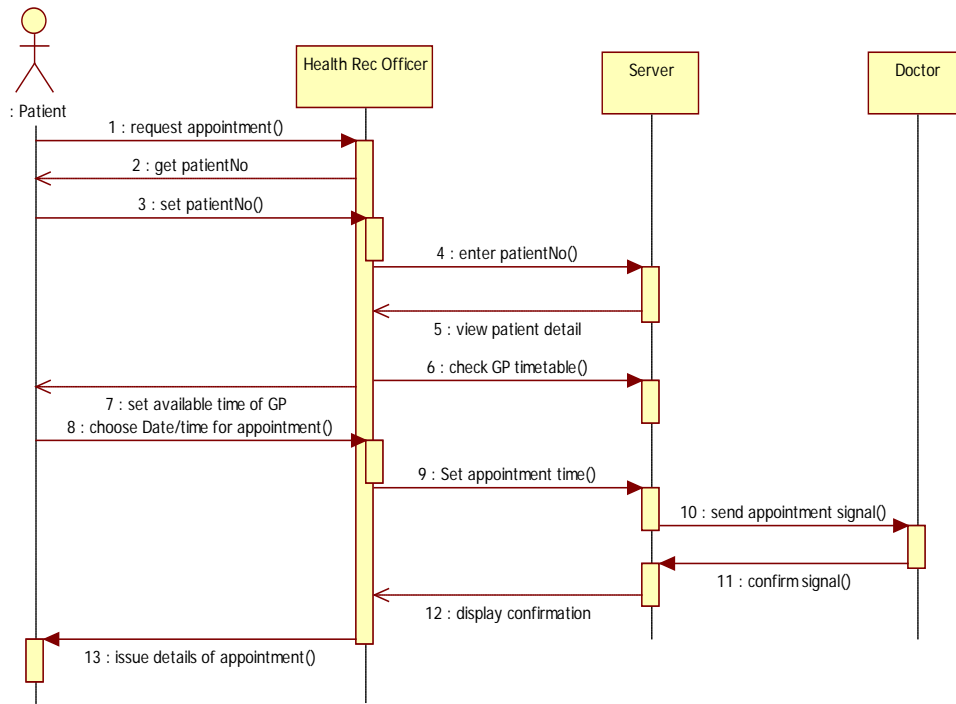

SEQUENCE DIAGRAM PATIENT BY THE AUTHOUR

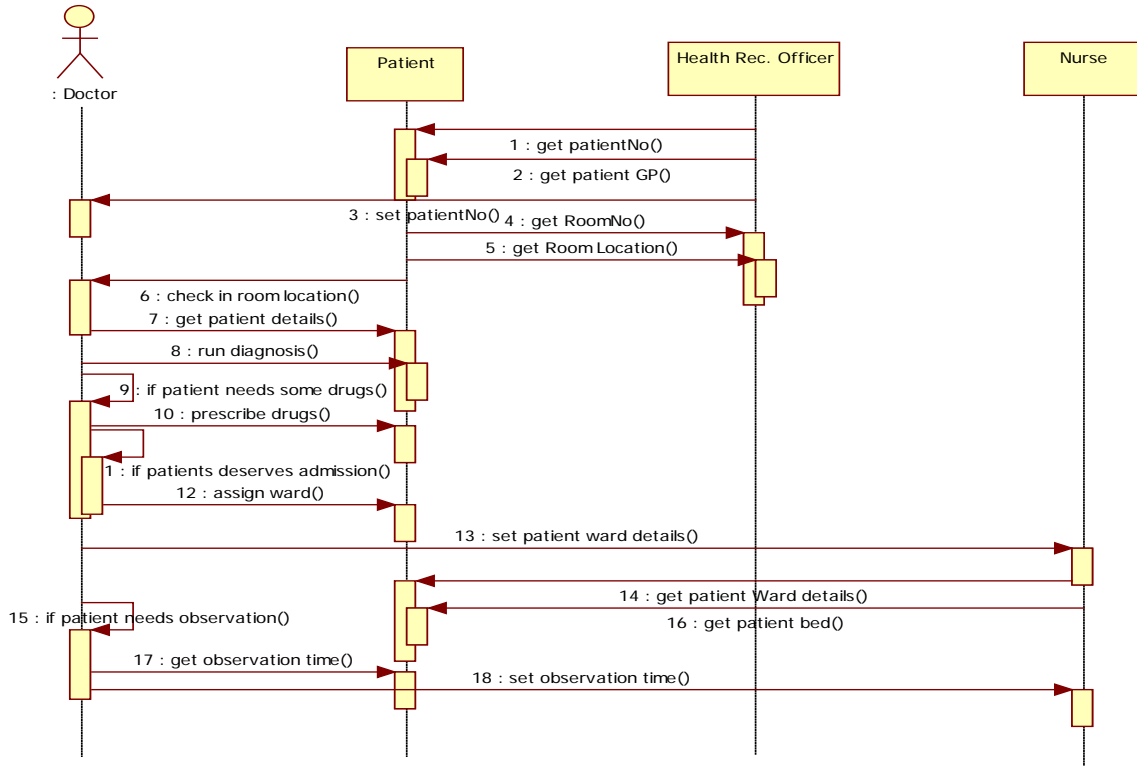

SEQUENCE DIAGRAM DOCTOR BY THE AUTHOUR

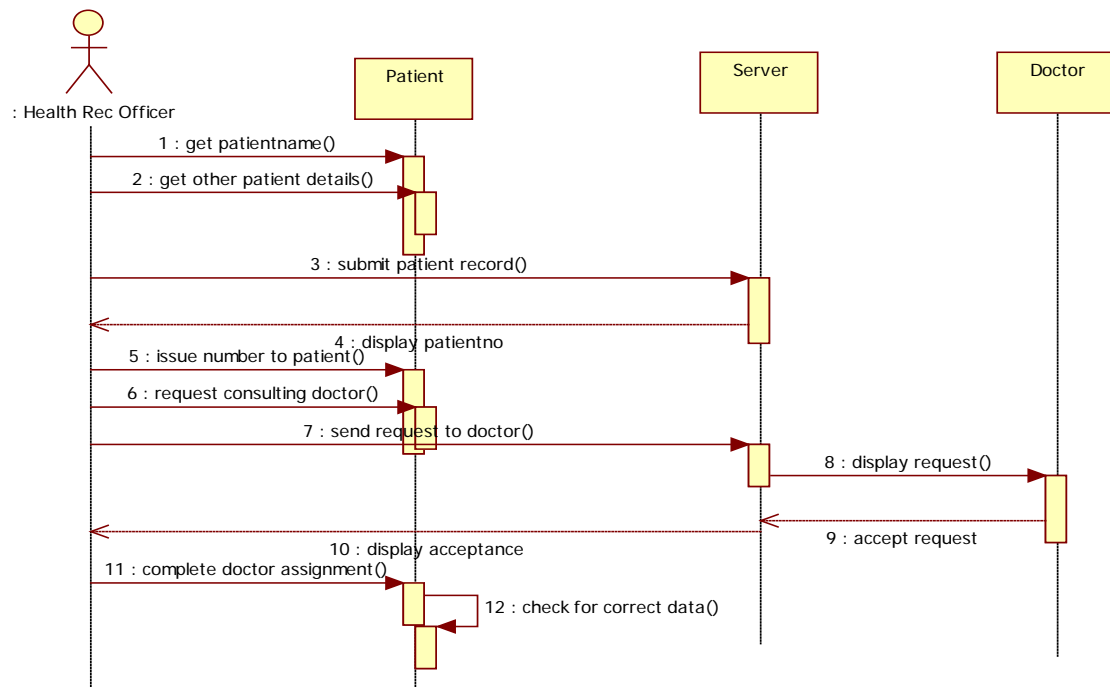

SEQUENCE DIAGRAM HEALTH RECORDS OFFICER BY THE AUTHOUR

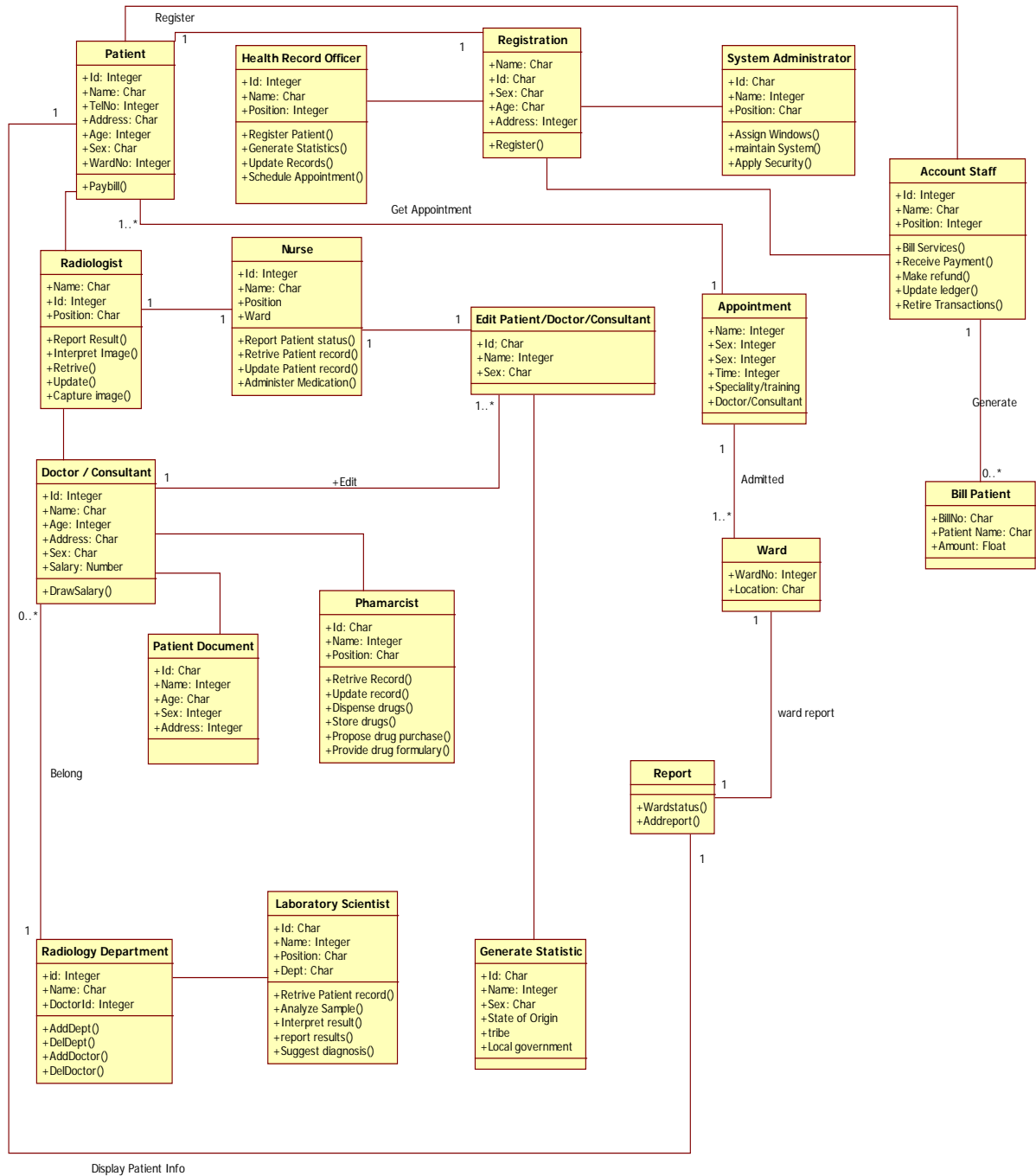

CLASS MODEL BY THE AUTHOUR

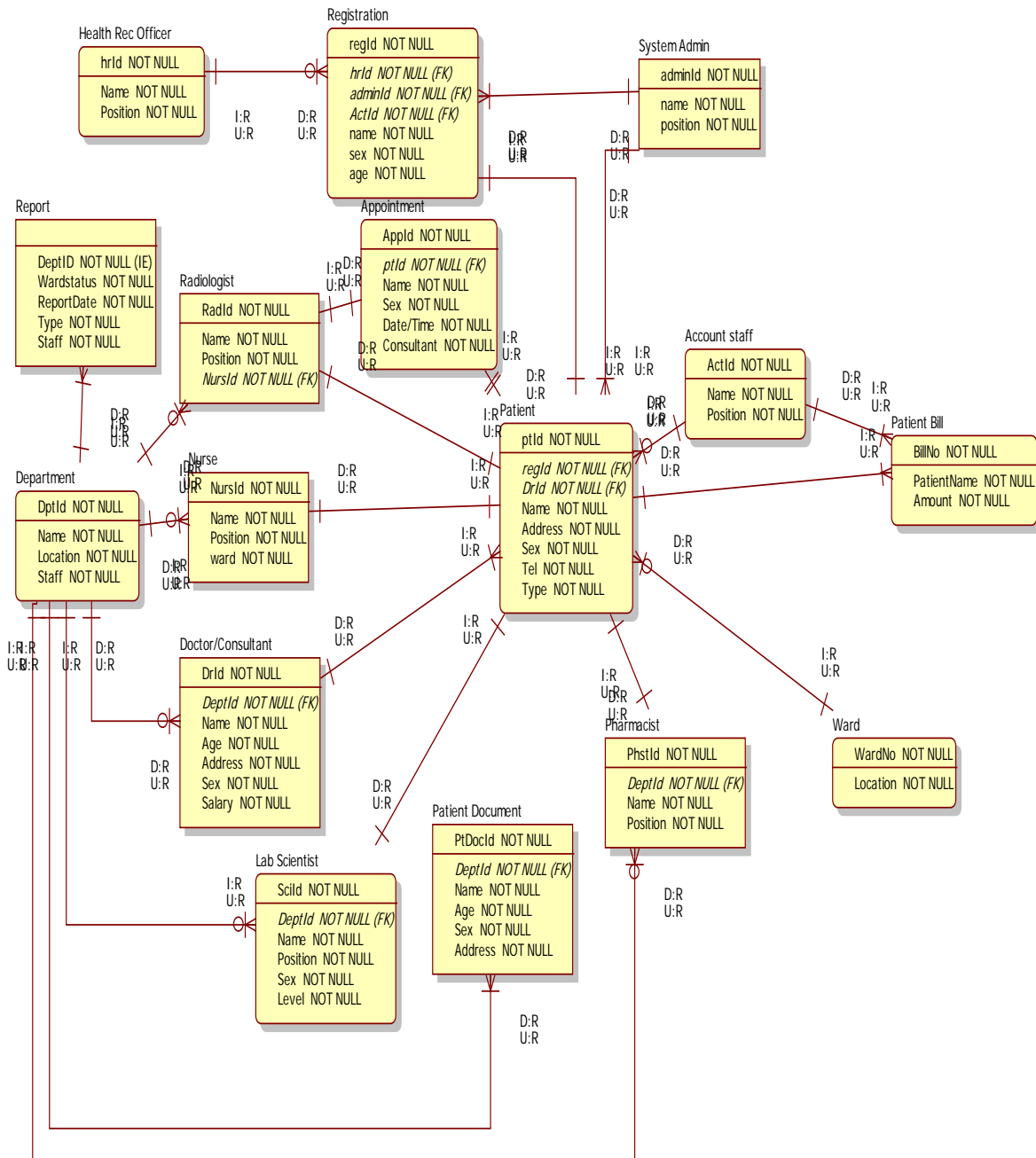

ENTITY RELATION MODEL BY THE AUTHOUR



## COMPARISON OF PROBLEMS SITUATION (REAL WORLD) APPRECIATED WITH CONCEPTUAL MODELS

Table 1: Comparison of problems situation appreciated with conceptual models

PROBLEMS APPRECIATED	SOLUTIONS IN THE CONCEPTUAL MODELS DESIGNED
Problem of patient without knowledge of where he was assigned to see a doctor	The model is designed where by health records officer will notify the doctor/consultant via server and doctor/consultant will respond back ready to see the patient and subsequently the patient will be notified.
In adequate and irrelevant list of drugs required for effective prescription.	Integration of pharmacy functions to update required list of drug formulary that can provide a list of drugs with their generic names
Lack of integration of ICD 10 and SNOMED CT	The ICD 10 and SNOMED CT are captured in the models designed.
Irrelevant list of diagnosis	The models have considered integrating ICD 10 and SNOMED CT which is useful in identifying list of diseases, operations, and procedures.
Problem of booking appointment	The model captured provision for scheduling of appointment.
Issue with referral	Model highlight referral functionality
Problem of statistical functionality	Statistics is captured in modelling for the proposed HIS, Software such as SPSS, EPI –INFO can be used to complement in statistical analysis
Lack of billing and costing functionality	Accounts functionality is addressed.
Multiple registration	The model is designed to register only one patient at time and double registration is eliminated using a unique patient ID cardinality consideration could help in this respect.

### DESIRABLE CHANGES AND CULTURALLY FEASIBLE

For the transformation of the hospital information systems to be more efficient and effective, this can be achieved through integration strategy of the data bases and effective migration strategy.

### CONCEPTUAL ACTIVITY OF MODELS OF SYSTEMS NAMED IN ROOT DEFINITIONS

The conceptual model and the root definition have been condensed to bring a transformation of an effective HIS for AKTH so that the hospital may continue its selfless service to humanity.

### CONCLUSION

The main Aim this paper is to analyse the existing current HIS system that is undergoing a phase implementation in a developing country of Nigeria. The methodology approach based on (SSM) and the data collection was the use of open ended questionnaire, this was adapted in order to obtain information necessary for requirement analysis.

## References:

- Adi M, 2001. *Health care Information systems challenges of the new millenium*. USA: Idea group.
- Anon., n.d. s.l.:s.n.
- Ardi A, 2001. *health care information systems*. USA: Idea group publishing.
- Ardi Armoni, 2001. *Health care information systems Challenges of the new millenium*. USA: Idea group publishing.
- Bennet S, 2010. *Object oriented systems analysis and design using UML*. 4th ed. Berkshire: Pearson education.
- Bergvall .B., APRIL 2004. Soft systems Methodlogy. *Systemic practice and Action research*, Vol 17(No 2), p. 57 to 61.
- Bergvall 2004, C. a. S. 1., 2004. Principles of soft systems methodology. *Systemic practice and Action research*, Vol(No 2).
- Bergvall B, wilson, 2004. Principles of soft systems methodolgy. *Systemic Action research*, Vol 17(2), p. 22.
- Blaya et al, n.d. *health affairs jpournal*.
- Brennan .S, 2005. *NHS Project the big*. Oxon: Radcliffe.
- Breu R. et al, February, 2009. Model based design of trustworthy health information system. *Seminar 09073*.
- Coiera E, 2003. *A guide to medical informatics*. London: Hodder Arnold UK.
- Davidson L.P, 2000. *Health Information systems*. USA: CRC PRESS LLC .
- Edna K Huffman, 2011. *Medical Records Management*. 2011 ed. Illinois: Physician records company.
- Garry et al, 2011. *Exploring strategy*. 9th ed. London: pearson Education england.
- Garry et al, 2011. *Exploring Strategy*. 9th ed. England: Pearson education.
- Gestafon D.H et al, 2007. *Investing in E-health*. Madison: Springer Science Business media.
- Hawryszkiewicz, 2001. *Systems analysis and design*. french forrest: pearson education Australia.
- J, T., 2008. *MINTIR*. 4th ed. London: western union.
- L, Adekoya, 2003. *How emerging technologies can aid health care*, London: City University.
- Rivero I.C et al 2006, 2006. *Database technologies application*. USA: Idea group publishing.
- Rodrigues J, 2010. *Health Information systems ,concepts,systems,tools and application*. London: IGI global london.
- Rossi P.H et al, 2004. *Evalaution a Systemetic Approach*. London: Sage Publication.
- Rossi P.H et al, 2004. *Evaluation a Systemic Approach*. London: Sage Publication.
- Sarawunmi .N., 2013. In the Spot light health information Systems. *IEEE Reviews in Bio medical Engineering*, Volume VOL 6.
- Sean Brennan, 2007. *The NHS IT project the biggest computer programme in the world ever*. Oxon London: Radcliffe.
- Sittig F and Hardeepising, 2012. Patient safety. *Journal of Medicine*, NOV.
- Tan J, 2005. *E-health Information systems an Introduction to professional*. San Fransisco: s.n.
- Thuraisingham B, 1999. *Data mining Technologies*. USA: Crc Press LLC USA.
- Wootton R. et al, 2006. Introduction to Tele Medicine. *Royal society of Medicine London*.
- Xu L D, 2011. *IEEE transactions on Industrial Informatics*. Vol 7 (No 4).