

VARIOUS METHODS OF ALUMINUM MELTING DUST DROSS FRACTION GRANULATION AND THE RESEARCH OF CONTINUOUS GRANULATION POSSIBILITIES

Ing. Jan Sedo

Mgr. Silvia Polakova

Ing. Daniela Cuchtova

Development And Realization Workplace Of Raw Materials Extracting And Treatment, Faculty Of Mining, Ecology, Process Control And Geotechnology, Technical University of Kosice

Abstract

Dust fractions from aluminum dross treatment are environmental load for every company in this industry sector. They are classified as waste due to their physical and primarily chemical parameters and require thus higher attention. On the other hand, the same parameters classify them as a possible source of chemical materials usable in other industry sectors. Dross treatment and the following treatment of their dust non-melting fractions are also important for such waste type producers as well as for product consumers produced from this waste.

Keywords: Dross, non-melting fractions, Confal Inc., environment, saving process

Introduction

Companies for aluminum dross treatment are in Europe concentrated in Western Europe, especially in Germany. There are concentrated the biggest capacities for aluminum and aluminum alloy production and waste from melting, therefore dust dross fraction treatment capacities are concentrated in this area. All companies use the technology of melting component leaching as they mainly treat dross from salt rotary furnaces. It is a predominant method of aluminum waste melting. This way of dust dross fraction supply for treatment is economically impassable for such a small company like Confal Inc., due to geographical position. A passive landfill is unacceptable as well for a company with environmental principles and it is an economically ineffective solution too. The company gets started with the

ways of dust dross fractions recovery seeking in its own conditions, the product creation ways seeking, and simultaneously with the processed gas product disposal in an environmentally appropriate way. The company made a partnership with Development and realization workplace of RMET, the Faculty of MEPCG, The Technical University of Kosice. The Innovative technologies for product creation from aluminum waste (dross) are the results of fruitful cooperation. This enables the reinvention of the company from leading Slovak aluminum waste processor to an innovative company with long-term stable position not only in Slovakia.

General dust dross fraction parameters from Confal Inc.

After crush and sieve sorting of aluminum material, fusible fractions with dimension of 0.8 mm are generated and fractions less than 0.8 mm are regarded as infusible i.e. they represent dust. The dust treatment requires a special attention due to its parameters.

Based on operational experiences, it is possible to say that:

- any internal logistics requires special attention because the finest fractions very easily enter the float and thus cause dusting the operating rooms;
- dust fractions must be inter-operationally stored in dry environment; they are more hygroscopic than unprocessed dross. The worst parameters have dust fractions of purchased dross separated in filter;
- immediate chemical reactions are initiated when in touch with any kind of moisture (air moisture, rain) and a mixture of flammable gases and ammonia is released. This property does not concern the dust fraction from rotary furnace which is almost „dead“ without any significant reactive capability;
- tribological parameters of material with content of Al_2O_3 above 60 % are very unfavorable from treatment point of view where moving rotary components are present. This fact controls the material solutions of active parts, particularly in crusher, in spiral conveyors and also exposed parts of air-conditioning technology such as arcs and places of fall apart. Increased requirements on material solutions are compensated by high sharpness of individual component separation of dust fractions from fraction above sieve size.

Granules generation by rolling of and their cohesion:

Distribution models of agglomerate generation from finer particles suppose that agglomerate generation (pellet) depends on fluid amount in the structure. The fluid must drench the surface of particle thoroughly in order to get effective mergence. The mechanism of particle mergence and force impact are described in (Pietsch, W.: Agglomeration processes). Basically

the fluid has to create effective bridges in the phase of pellet generation and growth. The final pellet strength depends on many co-factors. While the pellets sized less than 1 micrometer the strength depends on molecular, Van der Waals forces with diagram in Fig. 1, pellets sized more than 1000 micrometer create the strongest binding of bridges. The dependence of strength in strain on pellet size can be seen in Fig. 2 for the individual binding mechanisms.

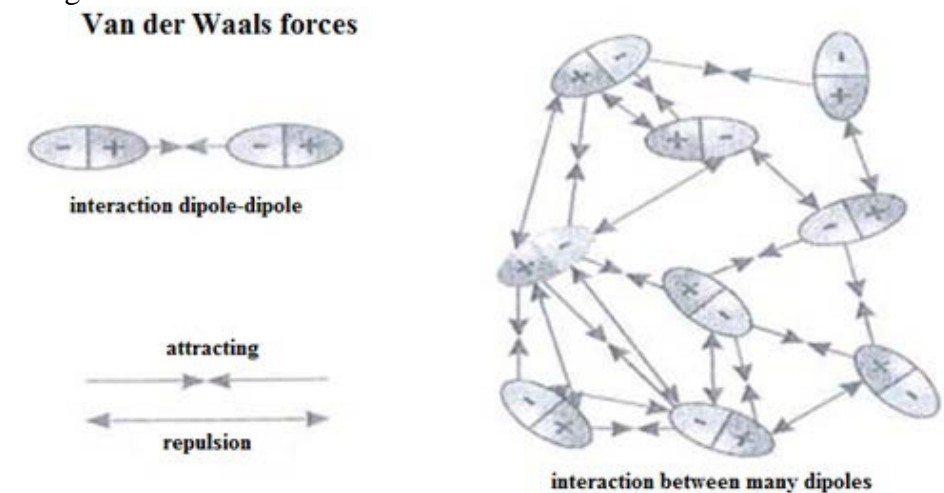

Fig. 1 Schematic illustration of Van der Waals forces

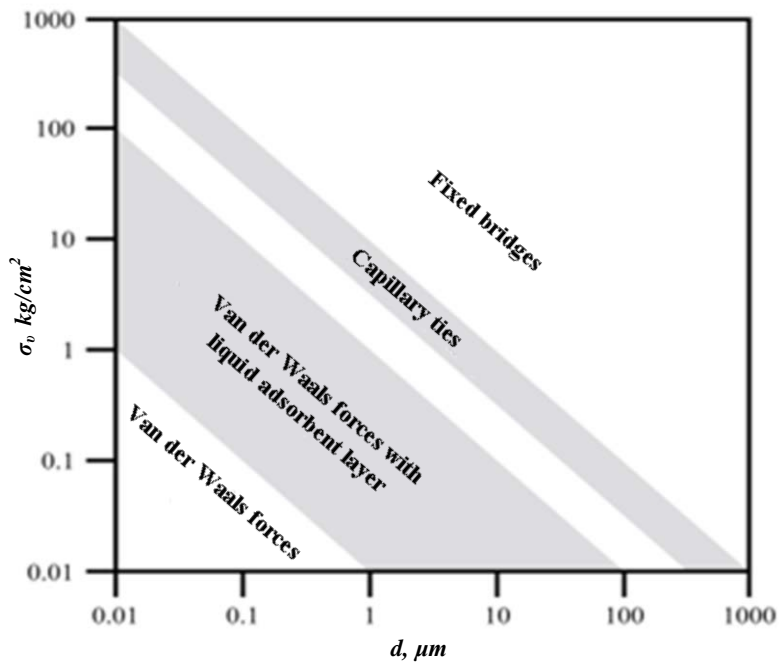

Fig. 2 Tensile strength dependency on granule size for individual binding mechanisms

We have material (dust) with various granularities at our disposal, from 0.8 mm to super fine granule size, therefore the ways of mutual bindings will be different. The aim is to create granules with size above 3 mm thus we suppose that granule seeds will be wrapped by finer particles between which Van der Waals forces prevail. More than 50 % of dust has the granularity under 100 micrometers with these coupling forces as most probable (Fig. 1). On Fig. 3 coupling forces are depicted. The cohesion between thickest particles is created by capillary forces (capillary vacuum), see Fig. 3a. The size of capillary forces is dependent on coupled particle radius and their radius is determined by capillary vacuum. The strength of these bridges is dependent on amount of liquid present. The condition is perfect moistening of particle surfaces. The creation of mechanical coupling forces (Fig. 3b) is possible when particles mutually reallocate during rolling off. For freely strewn dry material we suppose that fine particles fill up the space between rough particles, therefore such dust appears to be a compact mass with minimal gaps between granules. Moistening liquid penetrates harder into micro gaps and pores in this case. Liquid surface tension significantly prevents this also. Therefore moistening should happen as soon as possible and run continually. It is necessary mix the dust with liquid intensively. By disrupting the surface compactness in micro and macro volumes the granule moistening runs more quickly. The moistening process is supported by binders (know-how of the Confal Inc. company), that absorb water in more natural way than dust dross and it is transferred between particles. Adhesive and cohesive forces, capillary vacuum, surface tension of water and the binders create conditions for wrapping of rougher particles into finer particles and for their mutual cohesion.



Fig. 3 Coupling forces: a) capillary force model, b) mechanical bond model

The shape of particles plays also an important role. Magnified view of dust mix through microscope can be seen on Fig. 4 with 40x and 100x magnification. We can see more regular shapes of aluminum oxide (white) and irregular ragged skeletons (dark). Reference (Chen, D.: Development of aluminum dross-based material for engineering applications) describes RTG diffraction of such dust. Fig. 4(a, b, c, d) are illustrative.

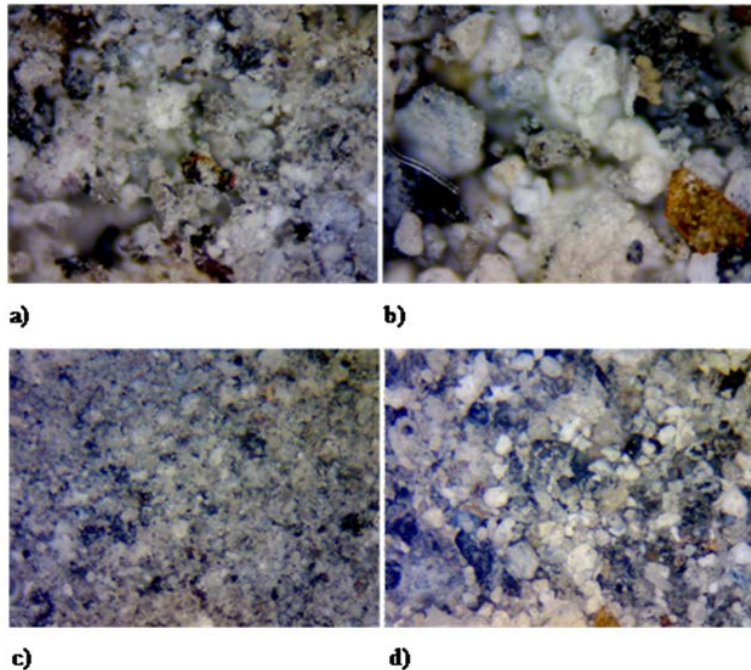

Fig. 4 Microscopy: a) unmodified dust 40x, b) leaching 40x, c) leaching 100x (detail from 4b), d) unmodified dust 40x

A very ragged particle surface with size above 0.1 mm significantly helps the water absorption and the coupling of finer particles on their surface. These are the seeds of granules. In places with randomly accumulated rough particles, clusters are created. In this bundling process oversized granules are created from these clusters. It is important that they should be able to disconnect during rolling off due to mechanical forces and form smaller granules. This crumbling mechanism is required and very probable because of significantly smaller granule firmness in places with rough granule clusters. Weak outer forces during rolling of do not create strong bindings between rougher particles. Granules with small size created by disconnection of greater ones have smaller tendency for crumbling. If no further crumbling occurs granules are structurally stable and during rolling of they are only compacted. Particles are reallocated into more suitable mutual positions and surplus water is pushed to the surface. When correctly moistened, the granule surface remains fine glazy and smooth. Sparsely moistened mix creates granules with dryer and rougher surface; therefore dust is created after chemical reactions end. During ramming by rolling off there is a shortage of water for finest particle distribution into pores between rougher granules. Excessively moistened mixture creates wet granules. The liquid washes the finest dust to wet and sticky granule surface during ramming. The inner volume remains porous; the gaps between rougher

granules are partially filled liquid and binder. Such granules do not have sufficient resistance against pressure when they are wet, they are thrown down in a layer and therefore they create clusters during chemical reactions easily. Strong adhesive couplings are created between them. Excessively moistened mixture transfers the finest substance onto granulating cylinder which is wrapped with material and binder that is capable to react.

Various methods of granule creation from dust dross fractions:

Based on knowledge of dust dross fraction parameters several methods of granule creation were tested in Confal Inc.

Granulation by wrapping in poppet granulator

Classical granulation by wrapping was made on lend poppet granulator which is depicted on Fig. 5.

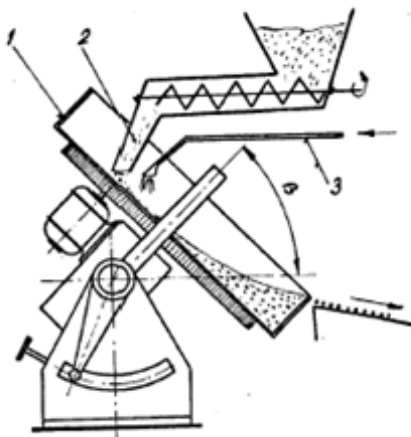

Fig. 5 Poppet granulator–diagram: 1 – granulating plate, 2 – dust batching, 3 - spraying

Screw conveyor batched continuously the dust material and sprayed water solution of binder – Duvilax BD 50/20. According to the requirements on products it was not possible to achieve sufficient granule strength; it was possible only by increased binder additions above 5 %. Such amount of binder caused elasticity of granules to some extent after they are dried, they seemed rubberized. Duvilax degradation occurred at higher temperatures than 130°C during exothermic reactions and granules fell apart. The tests with other binders were also negative as granules fell apart already after they fell out from granulator as they were insufficiently moistened in volume. Insufficient fine dust fraction wet ability prevents perfect moistening. Tests were discontinued due to small efficiency (to 200 kg per hour), inappropriate outputs and in the case of Duvilax BD 50/20 also the high price. We can say that this method is inappropriate for continual operation.

Granulation by extrusion

Tests were made with cooperation with VUCHT Inc., Nobelova 34, Bratislava in their laboratories as there was not available such a device otherwise. Test results are described in (Pellet test evaluation for Confal Inc.) and depicted on Fig. 6. X-axis represents the concentration of Duvilax (PVAc) and humidity for test groups. Y-axis represents stress forces and dust fractions after pellet creation. Basing on test results we can say that even at low binder content (till 2 %) of Duvilax BD 50/20 it is possible to create hard pellets with pressure strength above 70 N, water content cannot be higher than 13 %. With 20 % of water in pellets were crumbled after tumble, with less than 10 % of water pellets were not nearly created, cohesion was too low. We were not able to measure the real strength in push as the laboratory was equipped with device to measure in the range until 70 N. The strength was too high because pellets could be broken only by a hammer. The device shabbiness and efficiency is also questionable. Workers in VUCHT stated that the matrix and valve could be damaged by abrasiveness of such dust after several tons of pellets produced.

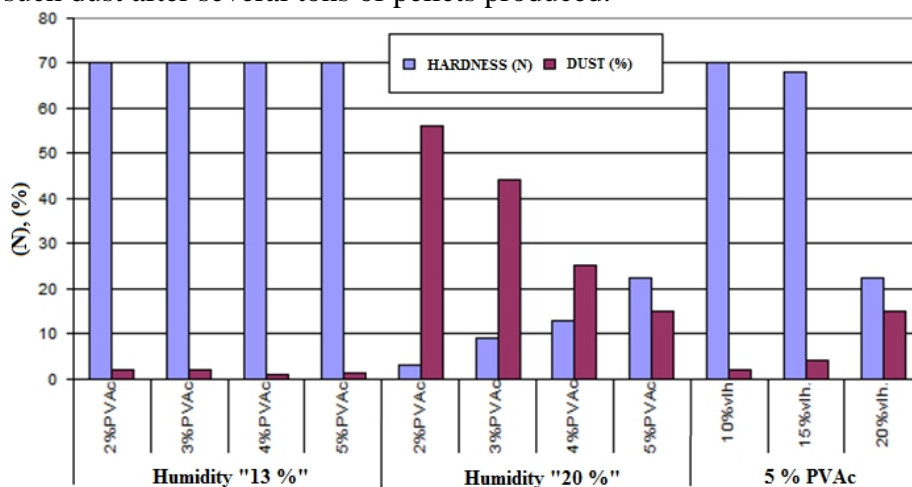

Fig. 6 Column diagram of pellet tests in VUCHT Bratislava
3.3 Granule production by roll off in doses

Basing on knowledge gained from classical granulator, we have built a pilot production line consisting of granulator like drum on chassis with drive. In this drum approximately 60 kg of binder and 25 % water mix have been moistened. Shovels in the drum removed the mix from walls and mixed up. Thus inappropriate wet ability of fine fractions was eliminated significantly. The binder was also changed and we used a combination of other binders instead of Duvilax due to high costs. In the mixture with dust this combination entirely removed all fortification shortages and at right reactivity (a combination of various dust types) the granules fulfilled entirely

all fortification requirements. The mixture of dust and binder was mixed and dosed into the bin.

We have placed a wrapper cylinder before mixing drum as a next step with 1000 mm diameter and 3000 mm length. The premixed dose was gradually powdered into the drum and granules were created in it.

In the framework of development program we have tested a model of continuous reactor that resembles shaft furnace (Fig. 7). It would be a nice solution but due to the stickiness of granules the reactor was sealed up or granules reacted late, after the reactor. Therefore it is unreliable for production. This is confirmed by thermal camera images Fig. 8(a,b,c). Chemical reactions were triggered at the start and the maximal temperature was on the bottom where reactions were supported by a small gas burner on PB, Fig. 7 - T5. Gradually as the reactor was filled, the range of maximal temperature moved to check point on the surface (Fig. 7 - T1), then to the whole volume and the reactor was sealed. Maximal temperature in reactor achieved by oxyacetylene heating was 150.5°C in check point on the top surface. Results and conclusion are described in (Internal documentation Confal, Inc.). We have made these tests because in literature (Hewitt, S.: Agglomerated alumina containing product) there is described such a system for drying as fully functional system and, moreover chemical reactions were supposed here. Such a system could be used in our case only for final drying of granules after their reactions when they are not sticky anymore to minimal residual humidity and with increased dustiness.



Fig. 7 Experimental device

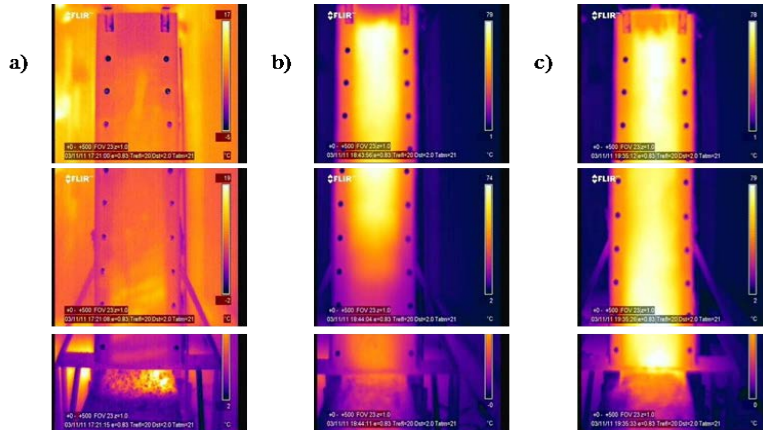

Fig. 8 Thermal camera images

The definition of requirements for continuous granulation by roll of for Confal Inc. company conditions

It was showed by tests in previous chapter that if the production line should operate continuously, it is necessary to fulfill some requirements:

- it was determined based on granulation tests form available sources that optimal granulation compound of dust dross fractions in Confal Inc. for granulation by roll of is nearly identical with compound of available inputs;
- it is necessary to find appropriate device for continuous moistening of premixed mixture with bindings and accommodate it to stickiness conditions and mixture abrasiveness;
- sufficiently long running time has to be ensured in granulation cylinder for sufficient fragmentation of moistened mixture, granule creation and sufficient granule compacting in wet state;
- the bonding of mixture on to the drum surface during granule creation has to be minimized (material solution);
- granules may react only after granulation cylinder;
- the layer thickness cannot cause their bonding by mutual pressure, at the same time intensive reactions have to be ensured;
- mutual granule movements after granulation device has to be minimized to avoid wet fragmentation;
- the chemical reaction must necessarily run in closed space from which gaseous reaction products have to be abducted;
- for process continuity granules have to be in reaction zone at least 60 minutes. As measured, this is the time needed for water loss to values under 5 % of residual humidity and granules remain intact in layer;
- conditions for chemical reaction restart and fall time have to be ensured;

- it is necessary to remove vapor from created gas (by condensation), its liquidation and energy balance can be solved.

Conclusion

The continual granule production from dust dross fractions without pre bleaching of soluble compounds is logistically challenging process. Production line has to take into account the dust material parameters, time behavior of individual steps and consequent physical-chemical processes. As the result we have nearly dry granules with residual humidity till 5 %, which is decreased till 1 % after 24 hours by after-reactions in closed space. The liquidation and gas energy content is an individual chapter of research for next period.

Acknowledgements

„This contribution/publication is the result of the project implementation Advanced technologies for environmental, energy and economic recovery of technogenic waste and raw materials, supported by the Competitiveness and Economic Growth Operational Programme funded by the ERDF“ (ITMS: 25110320041)

References:

- Sedo, J. (2013) In: Company presentation of Confal Inc., Waste - Secondary Raw Materials 5, 5th International Conference, Liptovsky Jan
- Pietsch, W. (2002) In: Agglomeration Process, Phenomena, Technologies equipment, Wiley-VCH Verlag GmbH, Weinheim.
- Hermann, P. (2011) In: Fertilizer granulation process, thesis, University of Pardubice
- Chen, D. (2012) In: Development of aluminum dross-based material for engineering applications, Worcester Polytechnic Institute
- Heinrich, V. (1984) In: Mechanical Processes, Slovak Technical University, Bratislava
- Report: Evaluation of pelletizing trials for the company Confal Inc., Bratislava VUCHT (2008)
- Internal documentation of Confal Inc., Slovenska Lupca, 2008 - 2014
- Hewitt, S. (2011) In: Agglomerated alumina containing product, International Publication Number WO 2011/092632 A2, 6573 Port Elizabeth, ZA.
- Research on properties of the intermediate gaseous substances resulting from the processing of aluminum dross, CA Zassi, TU of Kosice (2012)
- Merker, G. (2007) In: Bauxite and Alumina Seminar, Athens STU, Bratislava.