

REVIEW ON MULTIPLEXING TECHNIQUES IN OPTICAL COMMUNICATION SYSTEMS

Ekta

Research Scholar, CT Group of Institutions , Jalandhar (Punjab), India

Vikrant Sharma, Research Scholar

Dr. Dalveer Kaur, Assistant Professor

Punjab Technical University Jalandhar (Punjab), India

Abstract

In this paper, we present an overview of different multiplexing techniques. We focus on TDM, FDM, WDM, DWDM and CWDM. Basically multiplexing is an important part of communication system in which large number of users send data at the same time through a single link. Multiplexing is widely used in communication systems due to its potential to increase the channel utilization or transmission capacity and decrease system costs.

Keywords: OFC, WDM, DWDM, CWDM, FDM, TDM, MUX, DEMUX

Introduction to OFC

OFC is a technique which is used for communication purpose. In OFC the information is transferred in the form of pulses over long distance through an optical fiber offers higher data rates. Basically optical fiber is a medium which carrier information from one place to another [1]. Optical fiber communication consist a transmitter section and a receiver section as shown in Fig:-1.The transmission device converts electrical signal into light signal, which is carried out by optical fiber cable at the receiver end .This light signal is converted back to electrical signal when a single mode fiber cable with small cross –section area is used for transmission of pulses it causes number of deleterious effects that damages the signal integrity in communication system. The telecommunication companies uses optical fiber to transmit telephone signals, internet communication, and cable television signals. The complexity of the fiber optic varies with respect to the distance [2].

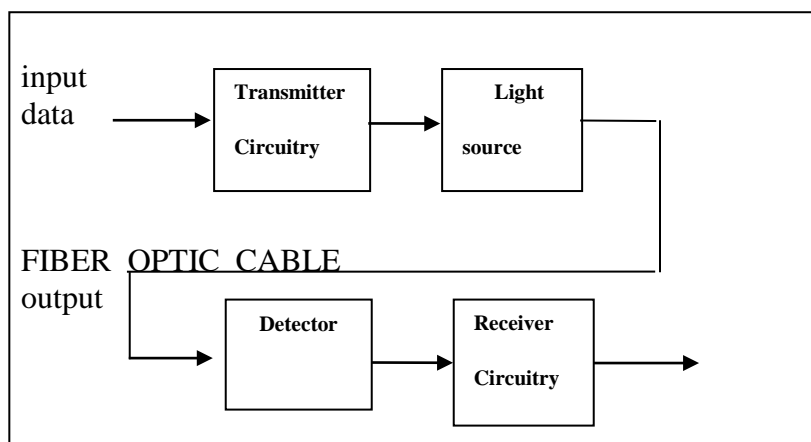

Fig:-1 FIBER OPTIC COMMUNICATION SYSTEM

Losses in fiber

Loss of light energy which is travelling in the form of light pulses from one end of fiber optic to another is called attenuation.

Optical fiber is also facing bending problem Called as bending loss.

Macroscopic bending and

Microscopic bending are the basic two types of bending loss.

Due to the microscopic variation in the material density, scattering loss is introduced. There are two types of scattering loss known as linear and non-linear scattering Rayleigh scattering loss, Mile scattering loss, and waveguide scattering loss comes under the linear scattering losses whereas (a) Stimulated brillouin scattering and (b) Stimulated Raman scattering are the types of non-linear scattering.

When an optical signal travels in the optical fiber, it gets distorted which is called dispersion. Intermodal dispersion and Intermodal dispersion are the two types of dispersion loss [3].

Multiplexing

Multiplexing is a technique, in which multiple users transmit data over a single channel. The channel may be co-axial cable, a fiber, radio or satellite.

Multiplexing is useful as to increase the channel utilization and the transmission capacity. Multiplexing has two devices called multiplexer (MUX) and De multiplexer (DEMUX) Multiplexer combines the different signals into a single signal. De- multiplexer performs the inverse operation of multiplexer [4].

Types of Multiplexing:-Multiplexing is mainly of two types Analog and Digital. Analog multiplexing technique is further classified into FDM

(Frequency division multiplexing) and WDM (wavelength division multiplexing).Where as digital multiplexing is has only one type called TDM (Time division multiplexing) as shown in Fig:-2.

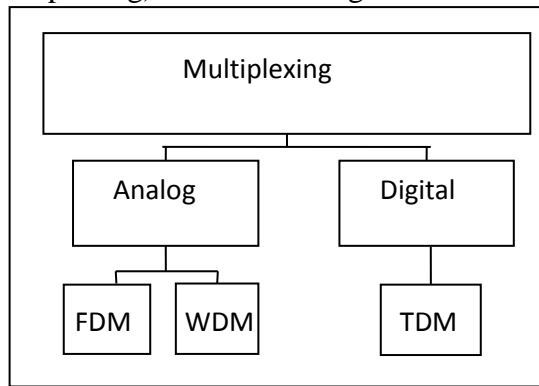

Fig:-2. TYPES OF MULTIPLEXING

TIME DIVISION MULTIPLEXING:-Time division multiplexing is a type of digital process. Fig:-3 shows Time division multiplexing. When data rate capacity is higher than the data rate required by sending and receiving time division multiplexing is used. The multiplexer and de-multiplexer needs to operate at equal frequency to the total combined bit rate ,Which is faster than the bit rate of single user by n times in TDM[4]-[5].

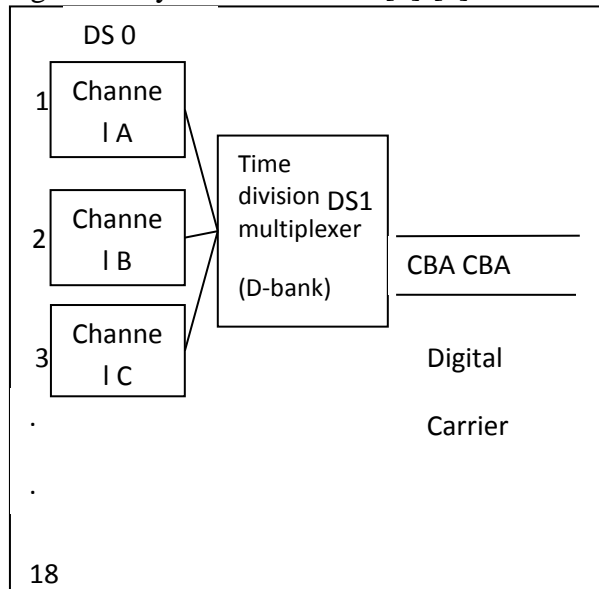

Fig:-3. Time division multiplexing

FREQUENCY DIVISION MULPTIPLEXING:-Frequency division multiplexing is an analog multiplexing technique in which different frequency is assigned to every signal within a common bandwidth [6] as

shown in Fig:-4. The signals are modulated in separate carrier frequencies using frequency modulation and amplitude modulation in frequency division multiplexing.

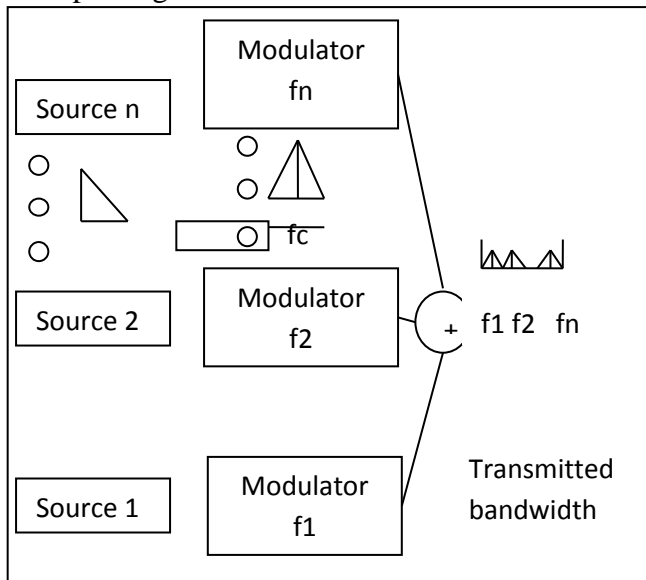

Fig:-4. Frequency division multiplexing

WAVELENGTH DIVISION MULTIPLEXING:-Wavelength division multiplexing is also an Analog multiplexing technique which uses optical fiber to carry many separate and independent optical channels. To increase the bandwidth of communication wavelength division multiplexing is used. The process of combining number of wavelengths onto a single fiber is called wavelength division multiplexing [7]. By reducing the channel spacing and increasing the bit rate we can increase the transmission capacity of wavelength division multiplexed systems. Low dispersion fibers and erbium-doped fiber amplifier are used in WDM systems to arise the demand for broadband information distribution. Fig:-5. Shows the Wavelength division multiplexing technique.

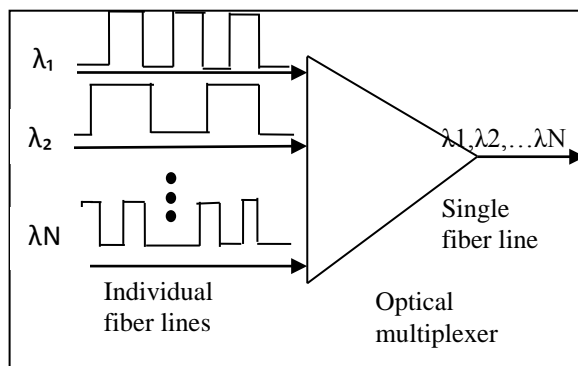

Fig:-5. Wavelength Division Multiplexing

From last few years wavelength division multiplexing plays a vital role for large capacity transmission systems.

First wavelength division multiplexing systems combined only two signals but modern WDM systems can handle up to 160 signals

Multiplexer is used at the transmitter end systems to combine the signals together and De-multiplexer is used at the receiver end systems to split the signals.

There are two types of wavelength division multiplexing.

- 1).DWDM (Dense wavelength division multiplexing)
- 2).CWDM (Coarse wavelength division multiplexing)

1).DWDM (Dense wavelength division multiplexing):- DWDM is the type of wavelength division multiplexing. DWDM is an optical fiber communication technique as shown in Fig:-6. The process of multiplexing many different signals onto a single fiber is called dense wavelength division multiplexing. Each fiber has a set of parallel optical channels each using different light wavelengths. Light wavelengths transmit data parallel-by-bit or serial-by-character. For long-haul transmission where wavelengths are packed tightly together DWDM is designed.

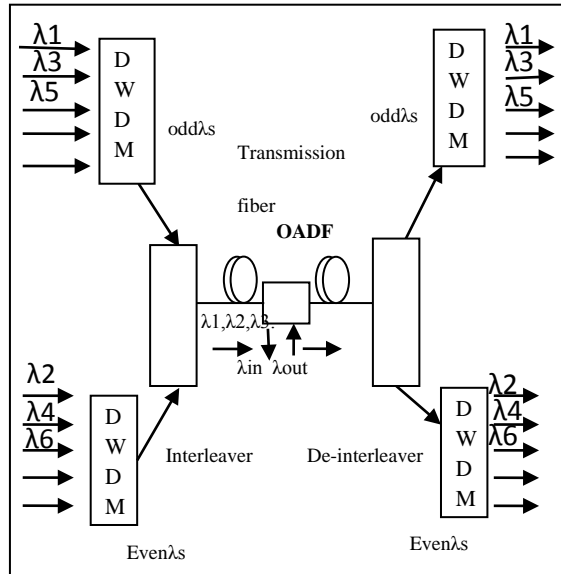

Fig:-6. DWDM SYSTEMS

2).CWDM (coarse wavelength division multiplexing):-Because the light signal of coarse division multiplexing is not amplified .It do not span long distances. Therefore the cost is kept down and also propagation distances are limits to maximum value. Fewer channels have been supported by the coarse division multiplexing and these channels may be adequate for metro carriers who prefer to start small and expand as the demand increases. The signaling systems which are not amplified keep the cost down with retaining high loss tolerance. There is often a trade-off between the capacity and distance every time when a non-amplified signal is used [8]. The two functions performed by CWDM are filtering of light and multiplexing or de- multiplexing of different wavelengths, which are travelling in a same medium.

Comparison between CWDM and DWDM		
Types	CWDM	DWDM
Channelspacing	20 nm	100 GHz/ 50 GHz/ 25 GHz
Cost	70 %	100 %
Laser	Un-Cooled Laser	Cooled Laser
Capacity	18 × 10 Gbps	192 × 10 Gbps
Application	100 Km	5000 Km

Table:-1. Comparison between CWDM and DWDM

References:

Aggarwal, G.P(2010), ‘Fiber Optics Communicat-ion,’ John Willey &sons Publications.
 Khurl, A.S. ; Saini, H.S.; Kaur, M (2009),‘Optical Fiber Communication’, India publishing House.

- Govind P. Agrawal (2006), 'Nonlinear effects in optical fiber', G.P Agrawal.
D. Ellis, D. M. Patrick, D. Flannery, R.J. Manning, D.A.O Davies, and D.M. Spirit, J. Lightwave Technol. 13,761(1995)
V.W.S Chan, K.L. Hall, E Modiano, and K.A Rauschenbach, J. Lightwave Technol. 16,2146(1998).
Watanabe, Shigeki. (2012) "ALL-Optical Data Frequency Multiplexing on single-wavelength carrier Light by Sequentially Provided Cross-Phase Modulation in Fiber." IEEE journal of Selected Topics in Quantum Electronics, Vol. 18, No. 2.
M. Yadlowsky, E. DeLiso and V.da Silva, "Optical Fibers and Amplifiers for WDM Systems", Proc. IEEE 85(11), 1997.
H. Yamamoto, K. Utsumi, M.Miyashita, M. Kurono, Y .Serizawa, Y.Shoji, H. Ogawa,"CWDM microwave optical links for fiber-optic sectorized remote antenna system", in Proceedings Microwave Photonics 2002 , pp. 241-244(2002)