

On The WH Question Particle [*wo*] In Yorùbá

Timothy Adeyemi Akanbi

Department of Linguistics and Nigerian Languages,
Ekiti State University, Ado-Ekiti

doi: 10.19044/esj.2016.v12n17p414 [URL:http://dx.doi.org/10.19044/esj.2016.v12n17p414](http://dx.doi.org/10.19044/esj.2016.v12n17p414)

Abstract

Every language has markers which are used in order to turn a positive sentence to an interrogative one; and native speakers of such language know the appropriate marker to use in any particular structure in order to ask questions or elicit information. Many of the WH question markers in Yorùbá are composed of one word. However, the question particle ...*wo* ‘when/which’³⁶, which is the focus of this paper, appears to be different in that it is composed of more than one word in its occurrence before it can function as a WH question marker. The focus of this paper is on this particular WH question particle (...*wo*) in Yorùbá. I argue that this particle is composed of more than one word before it can function as a question marker and turn a positive sentence to an interrogative one. In other words it must combine with either a prepositional phrase (PP) or a noun phrase (NP) and thereafter move to Spec-CP through movement rule of internal merge to check its WH interrogative feature for proper convergence at Spell-Out.

Keywords: Speakers, Internal Merge, Feature, Interrogative, Spell-Out

Introduction

Attempts have been made by scholars of linguistics to study and write on the interrogatives in various languages. Through their various

³⁶ This paper emanated and is based on the author’s personal communication with Prof. Abiodun of the Linguistics Department, Ekiti State University. Prof. Abiodun believes that *wo* underlined, and rendered in bold face, is the question marker in structures like the ones below:

Ní ìgbà <u>wo</u> ni Òjọ́ dé?	‘When did Òjọ́ arrive/return?’
Ní ojú <u>wo</u> ni Òjọ́ dé?	‘Which day did Òjọ́ arrive/return?’
Ní ọ̀sẹ̀ <u>wo</u> ni Òjọ́ dé?	‘Which week did Òjọ́ arrive/return?’
Ní ọ̀dún <u>wo</u> ni Òjọ́ dé?	‘Which year did Òjọ́ arrive/return?’

This writer believes that it is the whole prepositional phrase (and the noun phrase, as will be shown in this paper) inclusive of *wo* that should be regarded as the question marker and is the question phrase.

writings, it has been shown that there is no language that does not operate questions in its repertoire which is an indication that interrogation is part of Universal Grammar (UG) features. It has also been shown that there are markers present in every language which are used to turn a positive statement to an interrogative one. In every language, two types of question formations are attested; Yes/No or Polar question and WH or content question. Yes/No questions require just a yes or no answer while content questions require more than a yes or no. In fact in answer to a content question, a yes or no answer will be anomalous.

Just like any other language, Yorùbá has a way of forming questions; be it polar or content question. The markers or phrases used for each of these types of question formations are different. While polar question uses about four different markers, listed in (1), content questions have various markers listed in (2).

1 ***Polar question markers***

- (i) Ñjé
- (ii) Şé
- (iii) Ha...bi
- (iv) Şebí or Şèbí

2 ***Content question markers***

- (i) Ta ‘who’
- (ii) Kí ‘what’
- (iii) (N)ibó ‘where’
- (iv) Èlò ‘how much’
- (v) Mèlò ‘how many’
- (vi) Báwo ‘how’
- (vii) Kílódé ‘why’
- (viii) ...wo ‘when/which’

It needs be said that why the polar question markers are not sensitive to [\pm human], the same cannot be said of content question markers; they have distinctive features that set them apart from each other. In other words, all of them cannot occur in the same syntactic position. There are, therefore, distinctive features that set each marker apart from the other. For instance *Ta* ‘who’ has the feature [\pm human], *kí* ‘what’ has the feature [\pm animate], *báwo* ‘how’ has the feature [\pm manner], etc.

In discussing the issue of question marker/phrase in this paper, we divide the paper into four sections. Section one is the introduction. We present the theoretical framework for the study in section two. Section three is dedicated to the derivation of interrogative sentences in Yorùbá with emphasis on the question marker/phrase ...*wo*. Section four concludes the paper.

Theoretical Framework

The theoretical framework adopted for this work is the Minimalist Program (MP). Minimalist Program, as propounded by Chomsky (1993, 1995, 1998, and 2000) and others like Zwart (1993) assumes that every clause formation starts with the selection of lexical items contained within the lexicon (*Operation Select*). Every word within the lexicon is believed to possess three universal sets of features which are <Sem, Syn, Phon> i.e. Semantic, Syntactic and Phonetic features. Syntactic derivation is formed by a simple mathematical operation called *Merge*. *Merge* is an operation which combines words selected from the lexicon with an already formed constituents or syntactic objects. Operation merge can be internal or external. It is known as *external Merge* when the operation combines words selected directly from the lexicon with an already formed constituents or syntactic objects; while it is known as *Internal Merge* when it recombines constituents within an already formed syntactic object. These and other operations such as *Attract* and *merge* within the MP are based on binary principle. Based on this, every operation of the type x, y is the set of elements that includes x and y . It means then that the binary nature of merge rules out ternary branching. MP ensures that the output of a syntactic derivation is not an arbitrary set but is derived from the input labels. For instance, the product of merge (α, β) can only be either an α -phrase or a β -phrase but not γ -phrase since γ was not part of the input in the first place (cf. Ilori and Oyebade 2012).

In MP, it is also assumed that every product of operation merge moves towards the interface level for *Spell-Out*. Spell-Out therefore, is the output of derivation at the level of pronunciation; i.e. *Phonetic Form* (PF). MP also ensures that every syntactic derivation converges at *Spell-Out* based on the compatibility of features of words employed in the derivation which must be checked against one another in the course of the process of derivation; otherwise, the derivation crashes.

Other MP assumptions, some of which, of course, are carry-overs from Government and Binding Theory (Chomsky 1981, 1986) are the *Split-IP Hypothesis* of Pollock (1989), and *Split-CP Hypothesis* of Rizzi (1997), which assume the splitting of the IP and CP projections into units within them in order to accommodate other elements that could move with the head in the process of *Internal Merge*. However, our analyses in this paper will make use of the IP and CP projections. The reason is because Split-CP of Rizzi (1997) is still controversial (see Newmeyer 2003b).

Formation of interrogative sentence in Yorùbá

The question markers/phrases listed in (2) above are used in the various sentences below (The question markers are rendered in bold face in each example).

- 3 (a) **Ta** ni Òjò rí?
QM FOC Ojo see
Who did Ojo see?
- (b) **Ta** ni ó rí Òjò?
QM FOC RP see Ojo
Who saw Òjò?
- 4 **Kí** ní Adé mú wá?
QM FOC Adé take come
What did Adé bring?
- 5 (N)**íbo** ni Şadé n lọ?
QM FOC Şadé PROG go
Where is Şadé going?
- 6 **Èlò** ni iṣu?
QM FOC yam
How much is the yam?
7. Ilé **mélòò** ni Bólá kó?
House QM FOC Bola build
How many houses did Bólá build?
8. **Báwo** ni ajá ṣe kú?
QM FOC dog do die
How did the dog die?
9. **Kílódé** tí Pėjú lọ?
QM Ptcl. Peju go
Why did Peju go?
10. Nigba (Ni ìgbà) **wo** ni Kúnle dé?
PP period QP FOC Kunle arrive
When did Kunle arrive/return?

It could be observed that in the various sentences above the question marker occupies the initial position in each sentence except (7) and (10)³⁷ where *iṣu* ‘yam’ a noun, precedes the question marker and *wo*, a question particle follows the preposition phrase (PP). However, there is a way to paraphrase the sentence in (7) and make the question marker appear at the initial position as seen in (11), though a little modification has to come in by inserting the particle *ní* within the sentence.

³⁷ The marker in (10) is the focus of this paper. Therefore, more will be said on it in the sub-sections below.

- 11 Mèlòó ni ilé tí Bólá kọ?
 QM FOC house Prtc. Bólá build
 How many houses did Bola build?

The question to be asked and answered here is; what is the strategy of deriving the WH questions. This question is addressed in the following section.

The derivation of WH question in Yorùbá

Virtually all the WH questions in Yorùbá are derived by fronting the WH marker. Through the movement rule of internal merge, the WH element is moved from its originating position to the Spec-CP. The Spec-CP, which is an empty position, is the already prepared landing site for the WH element. Spec-CP is a position for element with the feature [+N]; therefore, almost all the WH items in Yorùbá are of the feature [+N]. This is so because the underlying form of many of these WH items before they became a WH item is originally a noun³⁸. We shall illustrate this from the data below.

- 12 (a) Adé jẹ ịṣu
 Adé eat yam } Basic/underlying clause
 Ade ate yam }
- (b) Adé jẹ kí?
 Adé eat Wh } Derived clause with WH word
 Ade ate what? } (This, in other way, is called echo question)
- (c) Kí_i ni Adé jẹ t_i?
 QM FOC Adé eat } Interrogative sentence
 What_i did Ade eat t_i? }

The data in (12) above is the history of the derivation of WH questions in Yorùbá. This derivational history applies to virtually all the WH interrogative sentences in the language. As indicated beside each of the derivations, (12a) is the basic clause and the underlying form for the sentences in (12b) and (12c); we have the derived clause in (12b) with the noun ịṣu ‘yam’ turning to a WH item kí ‘what’. What we have in (12b) is what is called *echo question* in the literature. We have the *spell-out* form of the whole derivation in (12c). Here, the movement has taken place. In this instance, two operations come into play; they are *attract* and *merge*. The Spec-CP attracts the WH element in (12b) in order to satisfy its own feature

³⁸ The only exception here are *kílódé* ‘why’ and *báwo* ‘how’ which can be regarded as adverbs.

by checking its WH feature upon C of CP and then merges with the already formed structure. It is important to note that the movement in WH question formation in Yorùbá is effected before *Spell-out* otherwise; the derivation will not converge.

The issue of WH movement cuts across all WH questions in Yorùbá. The reason is because, unlike some languages, Yorùbá does not operate WH in-situ in the derivation of WH questions. In the next section, I discuss the issue of ...*wo* as question marker in Yorùbá.

...*wo* as WH question marker/phrase in Yorùbá

We present the following examples upon which our discussion in this section is based.

- 13 (a) Ní ìgbà (Nigba) wo ni Òjó dé?
 Prep time/period QP FOC Òjó arrive
 When did Òjó arrive/return?
 (Litt. At which/what time did Òjó arrive?)
- (b) Ní ojú wo ni Òjó dé?
 Prep day QP FOC Òjó arrive
 Which/what day did Òjó arrive/return?
- (c) Ní ọ̀sẹ̀ wo ni Òjó dé?
 Prep. Week QP FOC Òjó arrive
 Which/what week did Òjó arrive/return?
- (d) Ní ọ̀dún wo ni Òjó dé?
 Prep. Year QP FOC Òjó arrive
 Which/what year did Òjó arrive/return?
- 14 (a) Ìwé wo ni Olú rà?
 Book QP FOC Olú buy
 Which/what book did Olu buy?
- (b) Ilé wo ni Olú kó?
 House QP FOC Olú buy
 Which/what house did Olu build?
- (c) Aṣọ wo ni Bólá wò?
 Cloth QP FOC Olú Bólá wear
 Which/what cloth did Bólá wear?

It has been argued that in structures like those in (13) and (14) above, the WH question marker there is *wo* (Personal communication with Prof. Abiodun). We do not agree with this assertion, rather, we believe (and we shall argue in support of this belief) that the totality of the whole prepositional phrase or noun phrase, as the case may be, should be regarded, and is regarded, as the question marker; hence, our convention of writing this WH question marker as ...*wo* (a kind of *x wo* where *x* can either be a prepositional phrase or a noun phrase or any other phrase for that matter).

The implication of our assertion here is that instead of having just an item as the WH question marker, in structures where *wo* occurs, we have a phrase that serves as the question marker. Our arguments in support of this assertion are presented in the sub-sections below.

The inability of *wo* not being able to move independent of the PP or NP

As we have earlier said, the derivation of WH question in Yorùbá involves turning the NP in the subject, the object or the adjunct position to a WH element and moving it to the Spec-CP of the whole sentence through the process of internal merge (see the examples in 12 above). This WH element that is moved leaves a copy of itself at the originating site; this copy represented by *t* is co-indexed with the moved WH item at the Spec CP position which is the landing site as shown in (15) below.

- 15 (a) Ta_i ní Òjò rí t_i?
 QM FOC Òjò see
 Who_i did Òjò see t_i
- (b) Ta_i ni ó_i rí Adé?
 QM FOC see Adé
 Who saw Adé?
- (c) (N)íbo_i ní Olú ti rí Adé t_i?
 QM FOC Olú Ptcl see Adé
 Where_i did Olú see Adé t_i

In (15a), the movement is from the object position; it is from the subject position in (15b), while the movement is from the adjunct position in (15c). In (15b), where the movement is from the subject position, a resumptive pronoun *ó* (which some scholars like Awobuluyi³⁹ designate as High Tone Syllable (HTS)) is inserted. The reason for this is because (i) Yorùbá language does not tolerate leaving its subject position empty and (ii), the sentence will not converge without the insertion *ó*, hence, the sentence crashes after spell-out. In the language of Government and Binding (GB) theory (Chomsky 1981), the *ó* is inserted for proper government (cf. Sonaiya 1988). In the case of (15c), the originating site for the moved item is the adjunct position. When a movement is from the adjunct position in Yorùbá, the insertion of *ti* designated as particle⁴⁰ is obligatory without which the sentence fails to converge. We show the tree configuration of the structure in (15a) in (16) below.

³⁹ See Awobuluyi (2001, 2006) for his arguments on this issue

⁴⁰ Readers are referred to Sonaiya (1988), Ajiboye (2005) for the argument on why this [ti] must be inserted. They also argue on the function of this particle [ti]. Repeating their various arguments here in this paper will amount to tautology.

16 Ta ni Òjó rí?

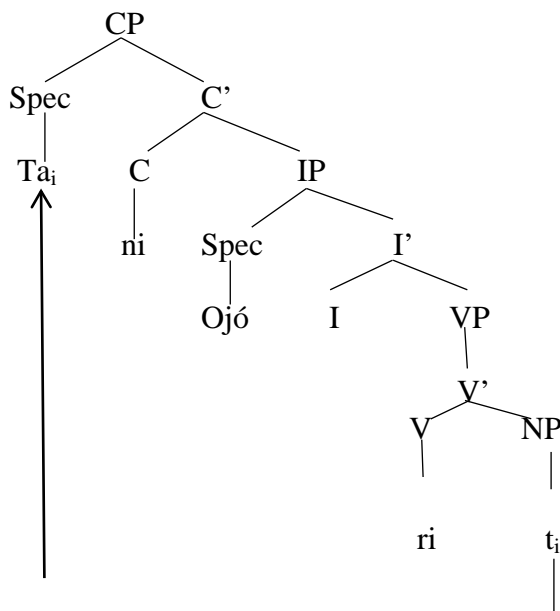

A close observation shows that the NP that was turned to a WH element is the item that was moved to the Spec-CP as in (16) above. This same process cannot be done for *wo* within the structure in which it appears. The reason is because *wo* cannot be the only element to which the whole PP or NP is turned to. In fact, there is no element within the structure that turned to *wo*. Consider the data below. We start the process from the underlying form of the clause used as interrogative sentence.

- 17 (a) Òjó dé ní alé àná
 Òjó arrive Prep evening yesterday
 Òjó arrived yesterday evening
- (b) Òjó dé ní ìgbà wo?
 Òjó arrive Prep period when
 When did Òjó arrive?
- (c) (N)ìgbà wo_i ni Òjó dé t_i?
 Prep period when FOC Òjó arrive
 When_i did Òjó arrive t_i

As can be observed in (17) above, the NP ‘alé àná, ‘yesterday evening’ was first turned into ìgbà ‘when’ and *wo* is thereafter inserted⁴¹. The whole PP together with *wo* is then moved to the Spec CP through internal merge and to its landing site. It is obvious that there is no element

⁴¹ The item *wo* is inserted so that the whole phrase can be turned to WH phrase. As will be shown, this *wo* has the feature WH within it which makes the whole PP or NP attracted to Spec-CP that has the feature WH to check.

within the structure in (17) that turned to *wo*. It is also very obvious that the preposition *ní* can be dropped during movement without rendering the sentence ungrammatical. When the preposition moves together with the NP the process is known as pied-piping in the literature (we will say more on this below). Because there is no element that is turned to *wo* in (17), this is why it is ungrammatical to render (17a) and (17b) as (18a) and (18b) below.

- 18 (a) *Òjọ́ dé ní wo?
 Òjọ́ arrive QM
 Òjọ́ arrived when?
 (b) *Wo ni Òjọ́ dé ní alé ànà?
 QM FOC Òjọ́ arrive Prep. evening yesterday
 *When did Òjọ́ arrive yesterday evening?

The ungrammaticality in (18a) and (18b) is due to the fact that there is no element that turned to *wo* within the sentence. Besides, it shows that *wo* alone cannot be regarded as the (only) WH question marker/phrase in the structures in (17) and many like them. This goes to show that it is the whole PP adjunct that serves as question phrase and marks the structure as an interrogative sentence.

This same scenario is observed within a sentence where NP rather than the PP is the complement of the verb. We give examples by starting with the underlying clause.

- 19 (a) Adé ra ìwé
 Adé buy book
 Adé bought a book
 (b) Ade ra ìwé wo?
 Adé buy book QP
 Ade bought which book?
 (c) Ìwé wo_i ni Adé rà t_i?
 Book QP FOC Adé buy
 Which book did Adé buy?

One important fact that manifested in (19) above is that *wo* which is designated as question particle (QP) is inserted in the position where it occurs. It did not originate from the underlying position. However, the insertion of this QP came up before Spell-Out for the sentence to converge at the level of the Phonetic Form (PF). The configurations in (20) and (21) below show the analyses of (17c) and (19c) above.

20 Nígbà wo ni Òjó dé

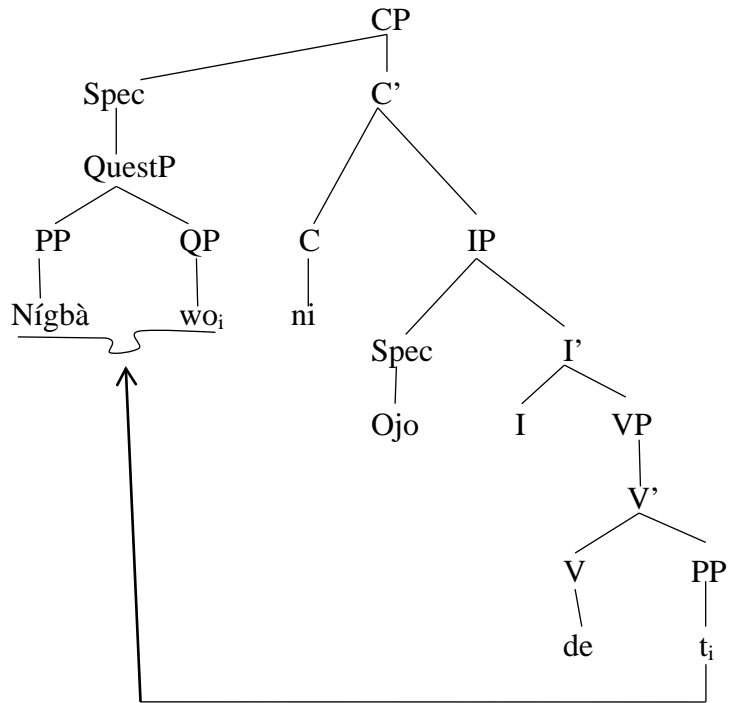

21 Ìwé wo ni Adé rà?

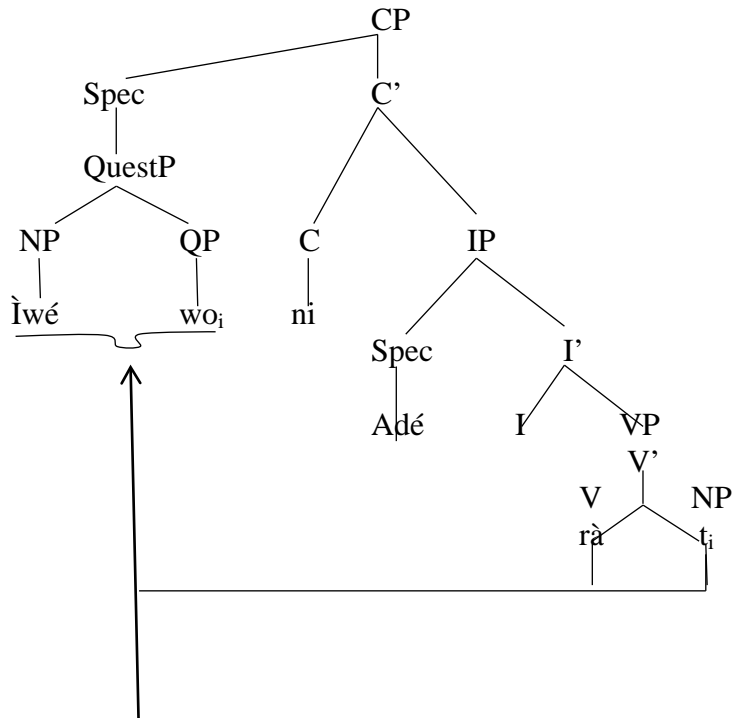

The two configurations in (20) and (21) show the analyses of the two types of structures where *wo* occurs.

Another issue to be resolved is ‘at what point does the insertion of *wo* take place?’ We posit that item *wo* is inserted before the internal merge of the PP⁴² or the NP as the case may be. This is done in order to turn the whole PP phrase or the NP phrase to an interrogative marker thereby serving as *attraction* for the Spec CP. There are two reasons for the insertion of this element. One, the Spec CP has a WH feature to check and except there is an item that has the feature WH, the checking will not take place, hence the insertion of *wo* upon which this Spec CP can check its WH feature. Second, the interrogative sentence of this type cannot converge without the insertion of this quasi-WH item, hence, the insertion of *wo* before Spell-Out at the level of PF.

The underlying form of *wo*

In this section, we shall investigate the underlying form of this item *wo*. This question particle (QP), we believe is *èwo* in its basic form. The vowel [e] at the initial position of the item normally gets deleted obligatorily in some environments within certain structures and optionally when it co-occurs with a Noun Phrase. When this item is rendered as *ewo*, it can be merged with an already existing clause by moving it to the Spec CP of such structure as shown in (22).

- 22 (a) Èwo_i ni Olú n wa t_i?
 QM FOC Olu PROG find
 What_i is Olu looking for t_i?
 (b) Èwo nínú wọn ní ó fẹ t_i
 QP Prep inside Pro FOC Pro want
 Which of them do you want?
 (c) Ìwé èwo_i ni Bólá rà t_i?
 Book QP FOC Bólá buy
 Which book_i did Bólá buy t_i?

In (22a), the *èwo* is designated as question marker for the fact that in this instance, it is substituted for *kí* which is one of the question markers in

⁴² We need to say at this point that the moved PP can be combined with any of the following NPs and even more:

- Ní ìgbà wo ni Òjó dé?
 Ní ojò wo ni Òjó dé?
 Ní ọsẹ wo ni Òjó dé?
 Ní ọdún wo ni Òjó dé?

It is not the *wo* underlined that is the only question marker but the whole Prepositional Phrase (PP) or Noun phrase (NP).

the Yorùbá language. In other words, the sentence can be rendered like (23) without any difference in meaning or resulting in ungrammaticality.

- 23 Kí_i ni Olú *ń* wá t_i?
 QM FOC Olú PROG find
 What is Olú looking for?

However, the case of (22b) is different in that the NP that should follow it has been optionally deleted, hence *èwo* is designated here as question particle (QP). It is still grammatical because in the environment where the NP precedes, this QP can be used. This is evident in (22c) where both the NP and this QP were moved together to the Spec CP. However, it is not even common for the native speakers to utter the sentence in (22c) as rendered. But we cannot rule out the fact that some speakers can still utter it as rendered in the written form.

But the situation is different when the same QP occurs in the environment after a prepositional phrase. First, the vowel [e] deletes obligatorily. Second, the PP with which it co-occurs also obligatorily moves together with *wo* to the Spec CP. This is illustrated in (24) below.

- 24 Nígba wo_i ni Şadé sòrò t_i?
 Period QP FOC Şadé say word
 When did Şadé speak?

It is therefore ungrammatical to render (24) in the form of structures in (25).

- 25 (a) *Nígba *èwo*_i ni Şadé sòrò t_i?
 Period QP FOC Şadé say word
 When did Şade speak t_i?
 (b) *Èwo_i ni Şadé sòrò t_i?
 QP FOC Şadé sòrò t_i?
 When_i did Şadé speak t_i?

The ungrammaticality in (25a) emanated as a result of retaining the vowel [e] of *ewo* which should have obligatorily deleted; while the ungrammaticality in (25b) is a result of moving only *èwo* which does not replace any item in the originating site to the Spec CP. The ungrammaticality is also due partly because there are no other items moved with *èwo* from the base position.

Báwo as another phrasal WH question marker

Apart from the question marker ...*wo*, there is one other question marker in Yorùbá which also makes use of ...*wo*; this question marker is *báwo* ‘how’. Observing the question marker *báwo* very closely, there is no doubt that it is made up of two syllables – *bí/bá* and *wo*. Can we say it is the last part of this morpheme *wo* that is the sole question marker? The answer definitely will be NO. In using the marker, the two morphemes must be

together before it can stand as a question marker – WH interrogative marker in this case. The example in (26) gives credence.

- 26 (a) Báwo ni ajá yìí se kú?
 QM FOC dog this Partc. die
 How did this dog die?
- (b) Báwo ni àwọn ọmọ wònyí se débí?
 QM FOC Qty child these Partc. come here
 How did these children arrive here?
- (c) Báwo ni o se mò?
 QM FOC 2sg Partc know
 How do/did you know?

A close observation on the use of this marker shows that it can only be used with the verbal particle *se*. We posit that this verbal particle reflects the [+manner] feature inherent in this question marker *báwo*. Further research may bring out other facts connected with the use of this verbal particle.

Before moving to some other evidence on this issue of WH phrase, it is important to note that no matter the number of items that comes between the PP or NP within a structure, the whole phrase before the FOC marker has to be regarded as the question phrase. It is this whole phrase that marks the sentence as an interrogative one. We give example.

- 27 Irú ọmọ alákorí burúkú wo_i ni mo rán t_i ní isé yíí?
 Type child incorrigible bad QP FOC 1sg send partc. work this
 Which type of a bad incorrigible child did I send on this errand?

The originating site of the whole WH phrase is represented by *t_i* and co-indexed with the moved question phrase including *wo* which was inserted before movement.

Evidence from some other languages

The phenomenon of having a phrase instead of just an item as question marker at the Spec CP of interrogative sentence is not peculiar to Yorùbá language alone. There are other languages that manifest this same attribute. Consider the sentences in (28) below taken from the English language.

- 28 (a) How many_i books did you buy t_i?
 (b) How much_i did John give Mary t_i?
 (c) Which book_i did Bill read t_i?

In (28) above, the *how* and *which* cannot be said to be the sole question markers in the sentences, it is the whole phrase that should be regarded as WH question phrase otherwise, the sentence will be ungrammatical (see 29a), (29b) and (29c). A speaker of English will agree

that it is the combination of the two morphemes that is used to mark the sentences as interrogatives.

- 29 (a) *How books did you buy?
 (b) *How did John give Mary?
 (b) *which did Bill read?

Neither can *many*, *much* nor *book* be used independent of the *how* and *which* as WH markers or else, ungrammatical sentences as the ones in (30) below will be generated.

- 30 (a) *Many books did you buy?
 (b) *Much did you give Mary?
 (c) *Book did Bill read?

Therefore, before the sentences can be adjudged as grammatical, the two items must be moved together to the Spec CP and be designated as the WH phrase that marks the sentences as interrogative ones.

As reported in Akanbi (2014), Akrofi-Ansah (2010) explains that in Larteh, one of the languages spoken in Ghana, a Kwa of Benue Congo phylum uses a phrase, rather than a word, as a marker of WH interrogation when enquiry is being made about time or period. The sentence below (31), taken from Akanbi (2014:281) corroborates.

- 31 Bere fene te/manke ne a bè-yó sukúú?
 Time how much in (time of day) FOC 3sg FUT-go school
 When will he/she go to school?

(Akrofi Ansah 2010:104)

In her paper, Akrofi-Ansah also reports that languages like Akan, (Saah 1988, 2000) and Ga (Kotey, 2002) also uses phrase and not just single item as WH interrogative marker when eliciting information that has to do with time/period.

Of much relevance to this paper is the work of Cheng (1991) where he identifies languages like Bulgarian, Romanian, Polish, Serbo Croatian and Czech to name just a few where multi question markers are used as WH interrogative items. As explained by him (Cheng 1991), Rudin (1988) proposes that the fronted WH-words in multiple fronting languages do not necessarily land in the same place. Rudin (ibid.) argues that the languages that manifest this type of interrogative markers are divided into two types: [+multiple filled Spec CP] languages and [-multiple filled Spec CP] languages. We believe that Yorùbá, in some instance, belongs to the first set of languages. The configurations in (32a) and (32b) represent the structural analysis of these two types of interrogative formations.

32 (a)

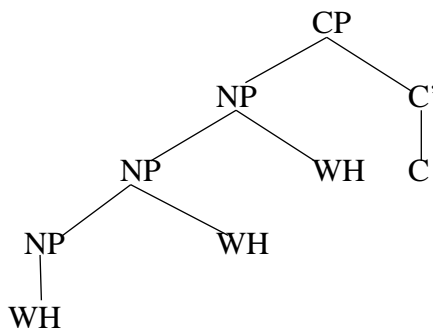

(b)

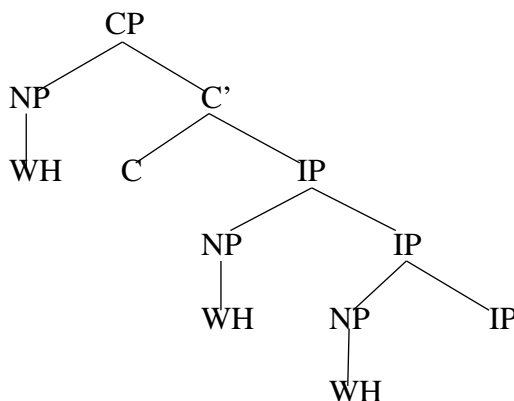

Cheng (1991) gives sentential examples for these two types of interrogative sentences that fall within those we have mentioned (interested readers are referred to Cheng 1991).

Following our arguments so far, we observe that Yorùbá language allows multiple adjunction to the Spec of CP in some instances. Besides, in structures where ...*wo* together with other elements are used as interrogative marker, allowance is giving for pied-piping while in some other uses of other interrogative markers, pied-piping is blocked. This informs why WH markers like *ta* ‘who’; *kí*, ‘what’, and some others cannot be used within a pied-piping structure.

Conclusion

We have argued in this paper in support of the fact that Yorùbá uses multiple interrogative markers in certain environments in the formation of its interrogative sentences. We posit that the marker *wo* which is regarded as the item that marks the sentence as interrogative one in (33) below cannot be regarded as such; but that the whole phrase ‘*Nígbà wo*’ is the WH question phrase that marks the sentence as interrogative.

- 33 Nigba wo ni Olú dé
 Period QP FOC Olú arrive
 When did Olú arrive/return?

Basing our arguments on series of examples, we posit that the item *wo* is inserted before the internal merge so that the sentence could converge. Not only this, since the Spec CP of such structures has WH feature, there is the need to check this feature against any WH element, hence the insertion of *wo*. This position is in line with Chomsky's (2000) assertion that 'movement must be triggered by a feature on a functional head'. This Chomsky's assertion is in tandem with the proposition of Rizzi (1997:282) taken from Newmeyer (n.d.:3) that "Syntactic movement ... must be triggered by the satisfaction of certain quasi-morphological requirements of heads. ... Such features have an interpretive import (Wh, Neg, Top, Foc, ...): they determine the interpretation of the category bearing them and of its immediate constituents ..." We therefore conclude that it is the *wo* within the sentence and the PP or the NP that give the interrogative marking, and that triggers movement to Spec CP hence, the whole phrase should be regarded as the WH interrogative marker/phrase.

To further buttress our position, some African, Asian and Indo-European languages that manifest multiple WH interrogative marking were alluded to and given as examples. There, we observe that the phenomenon found in Yorùbá also exists in the already mentioned languages used as examples in this paper.

References:

- Akrofi-Ansah, Mercy 2010. Focused constituent interrogatives in Larteh. *Nordic Journal of African Studies*, 19(2); 98 – 107.
- Ajíbòyè, Jacob O. 2005. Topics on Yorùbá nominal expressions. Ph.D. Thesis; The University of British Columbia, Canada.
- Akanbi, Timothy A. 2014. A descriptive account of Àhàn verb phrase. Unpublished Ph.D. Thesis, Ekiti State University, Ado-Ekiti.
- Awóbùlúyì, O. 2001. Arópò-orúkò kúkúró ẹnì kẹta ẹyọ aṣolùwà. *Yorùbá: Journal of the Yorùbá Studies Association*, Vol. 2, No. 1; 1- 8.
- Awóbùlúyì, O. 2006. 'Ó' kì í ṣe arópò orúkò nínú èdè Yorùbá. *Yorùbá: Journal of the Yorùbá Association*, Vol. 3, No. 3; 1 – 14.
- Cheng, L. L. 1991. On the Typology of WH-Questions. Unpublished Ph.D. Dissertation. Massachusetts Institute of Technology.
- Chomsky, Noam 1981. *Lectures on Government and Binding*. The Pisa Lectures. Dordrech: Foris.
- Chomsky, Noam 1986. *Barriers*, Cambridge, MA: MIT Press.
- Chomsky, Noam 1993. A Minimalist Program for language theory. In Kenneth Hale and Samuel J. Kayser (eds.). *The view from Building 20*.

Essays in Linguistics in honour of Sylvain Bromberger. Cambridge, MA. MIT Press.

Chomsky, Noam 1995. *The Minimalist Program.* MIT Press, Cambridge, Mass.

Chomsky, Noam 1998. *The Minimalist Inquiries: The Framework,* MIT Occasional Papers in Linguistics, No 15.

Chomsky, Noam 2000. *Minimalist Inquiries: The Framework.* In Martin, R., D. Michaels, and J. Uruagereka (eds.). *Step by Step: Essays on Minimalist Syntax in Honour of Howard Lasnik,* MIT Press, Cambridge, MA; 89 – 155.

Ilori, Johnson F. and Francis. O. Oyebade. 2012. *Negation in Igala. Entrepalavras, Fortaleza - ano 2, v.2, n.1, 25-40.*

Kotey, C. 2002. *Question formation in Ga.* Unpublished M.Phil. dissertation, University of Ghana, Legon.

Newmeyer, Fredrick J. 2003b. *Against the Split-CP Hypothesis. Generative Linguistics in Poland 5.*

Newmeyer, Fredrick J. n.d. *On Split-CPs, Uninterpretable Features, and the 'Perfectness' of Language.* University of Washington, 1 – 23.

Pollock, Joan Y. 1989. *Verb Movement, Universal Grammar and the Structure of IP. Linguistic Inquiry 20, 365 – 424.*

Rizzi, Lilian. 1997. *The Fine Structure of the Left Periphery.* In L. Haegeman, ed., *Elements of Grammar: Handbook of Generative Syntax.* Kluwer, Dordrecht, 281-337.

Rudin, S. 1988. *Multiple filled Comp interrogatives.* Ms.

Saah, K. K. 1988. *Wh-question in Akan. Journal of West African Languages, 18(1); 17 – 28.*

Saah, K. K. 2000. *Interrogative sentence in Akan.* University of Ghana/Utrecht Institute of Linguistics. Ms.

Sonaiya, R. 1988. *WH-movement and proper government in Yorùbá.* In Botne, R. and P. Newman (ed.) *Current Approaches to African Linguistics, 5: 20 – 36.*