

# THE APPROACH TO THE ANALYSIS OF ELECTRICAL FIELD DISTRIBUTION IN THE SETUP OF PAPER INSULATED ELECTRODES IN OIL

*Pawel Rozga, PhD*

*Dariusz Hantsz, MSc*

Technical University of Lodz, Poland

---

## **Abstract**

Article presents the problem of the approach to the analysis of electrical field distribution in the model insulating system, which, in the author's experimental research, was used to the assessment of the influence of paper insulation on the mechanism of electrical discharge initiation in mineral oil. The main assumptions of the planned numerical works based on the finite element method were described and scientific aim of the numerical analysis were characterized in this paper. Both the assumptions and the scientific aim were related to the conclusions from the experimental works, especially to the measured times to initiation of the discharges developing in mineral transformer oil, indicating on the important role of the oil quality in the process of discharge initiation in the system of the insulated by paper electrodes immersed in oil.

---

**Keywords:** Finite element method, paper-oil insulation, electrical field distribution, electrical discharges

## **Introduction**

Finite element method (FEM) in the electrical engineering issues has been used for many years. This method is mainly used as a method for description of the problems of potential and electrical field distribution in the insulating systems having very complicated shapes. Calculations with the usage of FEM are the indispensable help at the designing of insulating systems of high voltage electrical devices like power transformers, instrument and voltage transformers, chokes, capacitors etc. (Raicevic N.B. 1999, Khaligh A., Vakilian M. 2008, Ma A. Q., Zhang Z. S. 2012). From the other hand, this method has been also on the large scale used for the analysis of magnetic phenomena occurring in the transformers. Next

to the practical using of finite element method in the engineering issues, it may be also applied for the research works, where the electromagnetic phenomena are considered in order to solve the scientific problems or to confirm the empirical relationship by numerical calculations (Gafvert U., Jaksts A., Tornkvist Ch., Walfridson L. 1992). In such aspect, finite element method will be used in the planned calculations, where the simulations of electrical field distribution in the model paper insulated electrodes in oil will be performed.

Generally, FEM is the mathematically advanced method of the physics computations based on the digitizing of the specified surface or space on the finite elements averaging the physical state of the substance and then on the realization of the actual calculations only for the nodes of this digitizing. Beyond the nodes, determined feature is approximated on the basis of the values in the nearest nodes. If the calculated model has a shape and forcing symmetry, then only the part of tested object may be calculated in order to obtain the results faster. In the many cases, as in the following presented picture (Fig. 1) showing electrical field distribution in the fragment of insulating system of high voltage capacitor insulated by SF<sub>6</sub>, it allows on the limitation of considered issue to the surface analysis (2D) (Hantsz D. 2010).

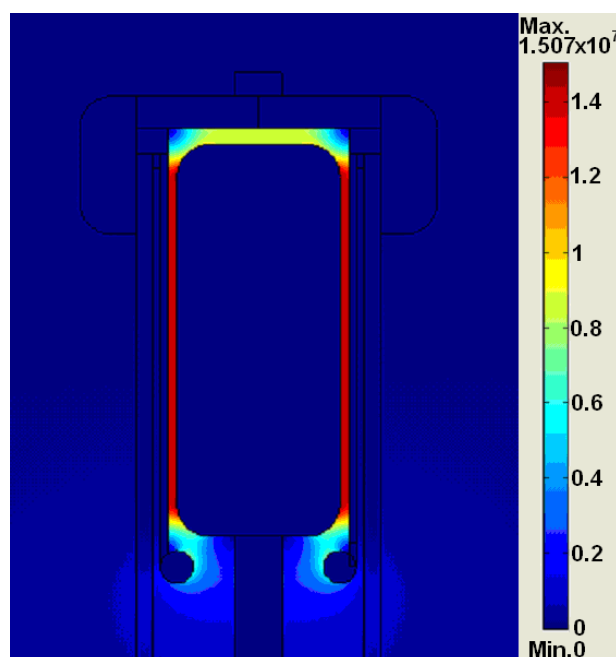

**Fig. 1.** Example of electrical field distribution analysis performed in the 2D space for the fragment of insulating system of capacitor insulated by SF<sub>6</sub>.

Using finite element method, the construction strength can be studied and the deformations, stresses (electrical, mechanical), transferences or liquid and heat transfers can be simulated. The dynamics, kinematics and statics of the machines as well as the

electrostatic, magnetostatic and electromagnetic effects can be also investigated. FEM calculations may be conducted in the two-dimensional space, where the digitizing is the most often brought to the division of the calculated area on the triangles. Such approach allows on the calculation of the values appearing in the section of the given system. However, some limitations are connected with such approach and they results from the specificity of the solved problem. Taking into account the progress in the field of computer science, in recent years the most of the simulating software is equipped with the possibility of solving the issues in the three-dimensional space, in which the digitizing of the considered area relies on the division on the tetrahedrons. In the considered case the second approach is necessary. The 3D space is determined by the shape of tested electrode model, which is not a symmetric system, thus using the simple 2D space does not give the reliable results. The fundamental of FEM is the possibility to obtain the results for very complicated shapes, for which the analytical calculations are not possible. It means that the given problem may be simulated in the computer memory without having to build a prototype, what greatly simplifies the design process. Dividing of the area into smaller and smaller elements typically results in more accurate calculation results but it causes increasing of the computing power of used computer. Visualization of the results is the presentation of the changing of given values in the form of colors from red and its tones, presenting the higher values, to blue with its tones, meaning the minimum values and zero (Fig. 1). At the simulation works, the important fact is the possibility of superposition of computational errors resulting from the multiple approximations of processed values. If area consists of hundred thousands of the elements, which have nonlinear properties, then the calculations must be appropriately modified in the next iterations in order to obtain the correct final solution. That is why, in exceptional cases, cumulative computational errors cannot be ignored. The aim of the minimizing of these errors between different versions of the same problem (for example, changing the material parameters at the same dimensions) identical digitizing is used in order to obtain the same rounding errors and to obtain the outcomes resulting from the relative changes of material properties.

#### **Approach to the considered problem**

Research works concerning the problem of electrical discharge initiation in mineral oil, in the system of bare and insulated electrodes include the wide range of experimental works carried out in the specially designed laboratories (Galczak J. 1999, Rozga P. 2010, 2011) as well as the simulating works supporting the inferences resulting from the experiments. Additionally mathematical modeling is also used for the assessment of the

processes occurring during the initiation and development of electrical discharges in oil (Beroual A., Fofana I. 1996, Aka-Ngui T., Beroual A. 2001). Planned author's simulating works on the analysis of electrical field distribution in the vicinity of electrodes covered by paper have to also confirm the hypothesis concerning from the studies performed for the real models of paper-oil insulations systems similar to the systems representing the electrical power transformers. During the above mentioned experimental works, in the wide range, the assessment of the discharge initiation and propagation mechanisms in the systems of insulate electrodes was made, but mainly the influence of paper insulation on the parameters characterizing the discharges like onset voltage, time to initiation, propagation velocity and on the shape of discharge forms and courses of light emitted by discharge channels, was studied. The measurements were conducted under lightning impulses of both polarities, in the technical purity mineral transformer oil, in the system with insulated high voltage electrode, with electrode stripped of its insulation and with bare electrode having the same outer dimensions as insulated one. The most important conclusion was connected with the measured times to initiation. The average values of these times, evaluated statistically, were almost identical when we take into account the insulated HV electrode and bare electrode having the same outer dimension as the insulated one, and when we compare the values measured at the same value of testing voltage (Table 1) (Rozga P. 2010, 2011).

**Table 1.** Times to initiation – log-normal distribution parameters

Voltage polarity	Electrode type	Testing voltage	Average values $t_d$ [ $\mu$ s]	Confidence intervals of average values [ $\mu$ s]
Positive	Insulated	190 kV	4.9	4.4 < $t_d$ < 5.6
	Bare	190 kV	5.0	4.2 < $t_d$ < 6.2
Negative	Insulated	192 kV	4.6	3.8 < $t_d$ < 5.5
	Bare	192 kV	4.7	3.7 < $t_d$ < 6.2

There is a hypothesis from the observations of the similarities of times to initiation that the source of "weak points" in the system with paper-oil insulation, where the technical purity oil was used for the investigations, is just the oil, not the metal surface of the electrode or the paper insulation. Thus, the oil as an insulating medium is, in the large measure, responsible for the strength of good conditioned insulating system with paper-oil insulation. The confirmation of this hypothesis is possible when we correlate the obtained times to initiation with calculated maximum values of electrical field stress in the both model electrode systems. If the obtained values will turn out to be the same, it will mean that the initiation of discharges occurs on the similar way, that is at the similar values of electrical

field stress. Thus, in both cases the similar volume of the oil will be under the electrical field stress higher than 90% of the maximum stress. If it will be accepted, that in this volume the number of weak points, which can be a source of the discharge initiation is in both cases identical, then the initiation process can be considered within a framework of the most stressed oil volume law. This law, formed for the most important of dielectric liquids used in the high voltage insulating systems (mineral oil), bases on the so-called volume effect. According to this volume effect, the electrical field stress, at which the development of discharges in oil and its breakdown happen, depends on the most stressed oil volume defined as a volume between the electrode of higher curvature and the equipotential surface of electrical field stress equals 90% of maximum stress. On the basis of such reasoning, for the uniform and quasi-uniform fields and for the bare and paper insulated electrodes in oil, the universal experimental relationships were derived. These relationships are independent on the configuration and interelectrode gaps, which define the electrical strength understanding as a electrical field stress, at which with certain probability the breakdown should happen (Murano M. et al 1976, Mosinski F., Wodzinski J. 1979). As an example of volume effect, the curve presenting the relationship between the electrical strength and oil volume for mineral oil at lightning impulse was shown in Fig. 2. The medians and the value of location parameter of the Weibull distribution fulfilling the definition of withstand voltage (having the breakdown probability 0%) are presented. The curves from Fig. 1 and 2 heads asymptotically for the fixed value of the most stressed volume.

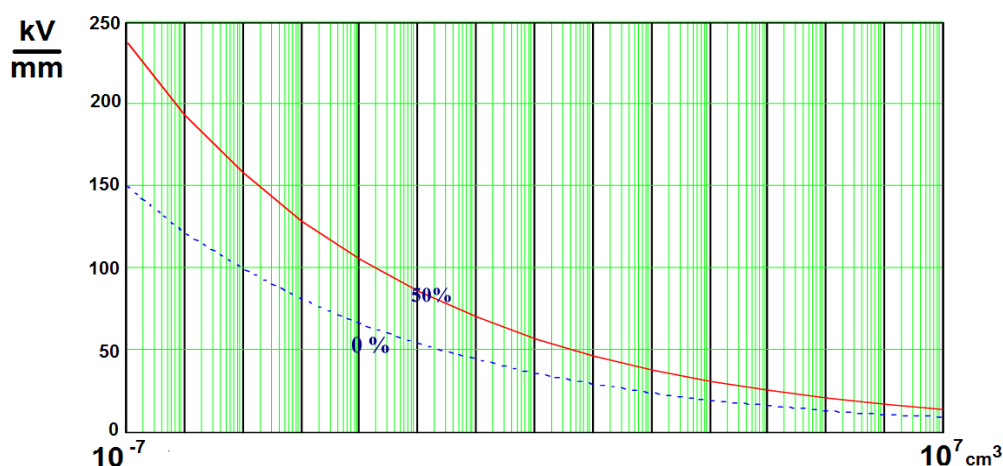

**Fig. 2.** Volume effect for mineral oil at lightning impulse (red line means median - 50% probability, blue line means location parameter of Weibull distribution - 0% probability).

Taking into account the considered case of electrode system with insulated and bare HV electrode, in the first step, according to the conditions imposed by the previously carried out experimental works, the precise geometric dimensions of both electrode systems and

physical features related to the materials of distinctive elements of the investigated system (dielectric permittivity  $\epsilon$ ) should be specified. The boundary conditions for the conductive elements must be also defined. The dimensions of the both electrode systems, showed in the cross section, were presented in Fig. 3.

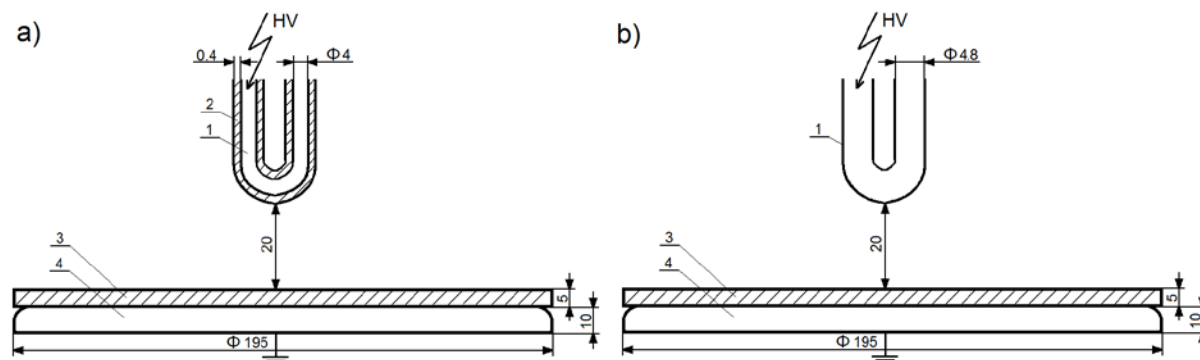

**Fig. 3.** Dimensions of electrode systems used during the experimental works: a) system with insulated HV electrode, b) system with bare HV electrode. Marks: 1 – brass rod, 2 – paper insulation, 3 – transformerboard insulating plate, 4 – grounded electrode.

Adopted the values of dielectric permittivity should be then as follows: for paper insulation on HV electrode and insulating transformerboard plate - 4 and for mineral oil - 2.2, while the values of electrical potential should be respectively 190 kV for HV electrodes and 0 for grounded electrode.

Important element at the planning of computational works is the choice of the software, which will be used for the analysis of electrical field distribution according to the accepted assumptions. For this purpose, the approach for the considered problem must be preceded by an analysis of the cases, for which the analytical calculation of maximum values of electrical field stress is possible. Obtaining the same results from the analytical calculation and numerical evaluation confirms the correct reasoning. In this field, the insulating system of two eccentric spheres in air was analyzed. This system allows on analytical calculation the values of maximum electrical field stress on the basis of the knowledge about the applied voltage  $U$ , interelectrode gap  $a$ , sphere radius  $r$  and coefficient of field nonuniformity  $\beta$  read for the relation  $a/r$ . A case, in which the first electrode had a potential equals 0 and the second, high voltage electrode had a potential  $U = 50$  kV, was considered. Dielectric permittivity, typical for air, was defined as 1. The rest of needed parameters were determined as follows:  $a = 1$  cm,  $r = 10$  cm and  $\beta = 1.03$  (for  $a/r = 0.1$ ). The value of maximum electrical field in the analyzed system obtained from the analytical equation was:

$$K = \frac{U}{a} \cdot \beta = \frac{50kV}{1cm} \cdot 1.03 = 51.5kV/cm$$

The field calculations performed for the same conditions gave the result 51,77 kV/cm, what was a lower than 1 % difference from the value calculated analytically (Hantsz D. 2010). In the Fig. 4 and 5 the visualization of the results in the form of distribution of electrical potentials and electrical field were presented.

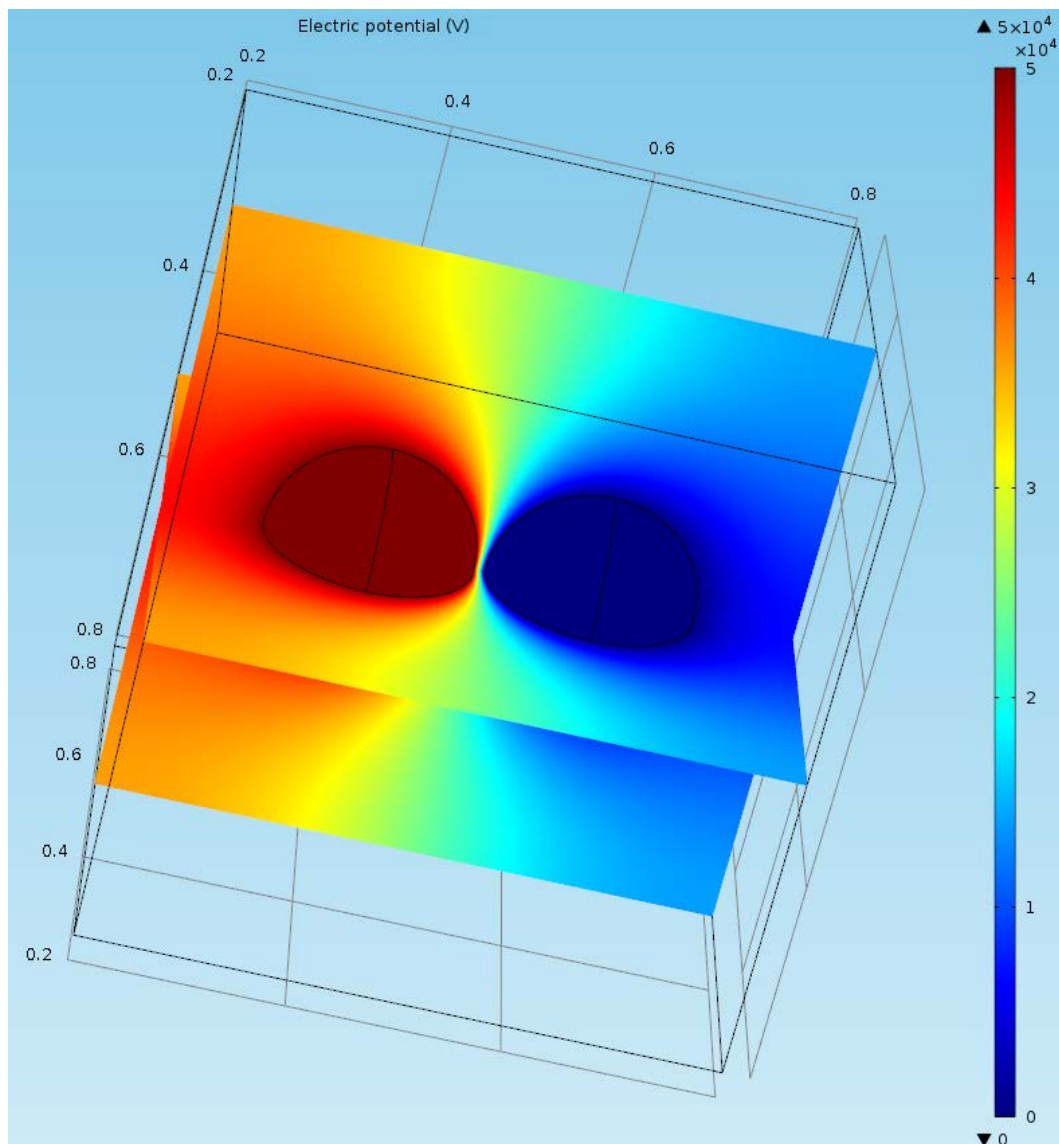

**Fig. 4.** Electric potential distribution for the system of eccentric spheres in air.

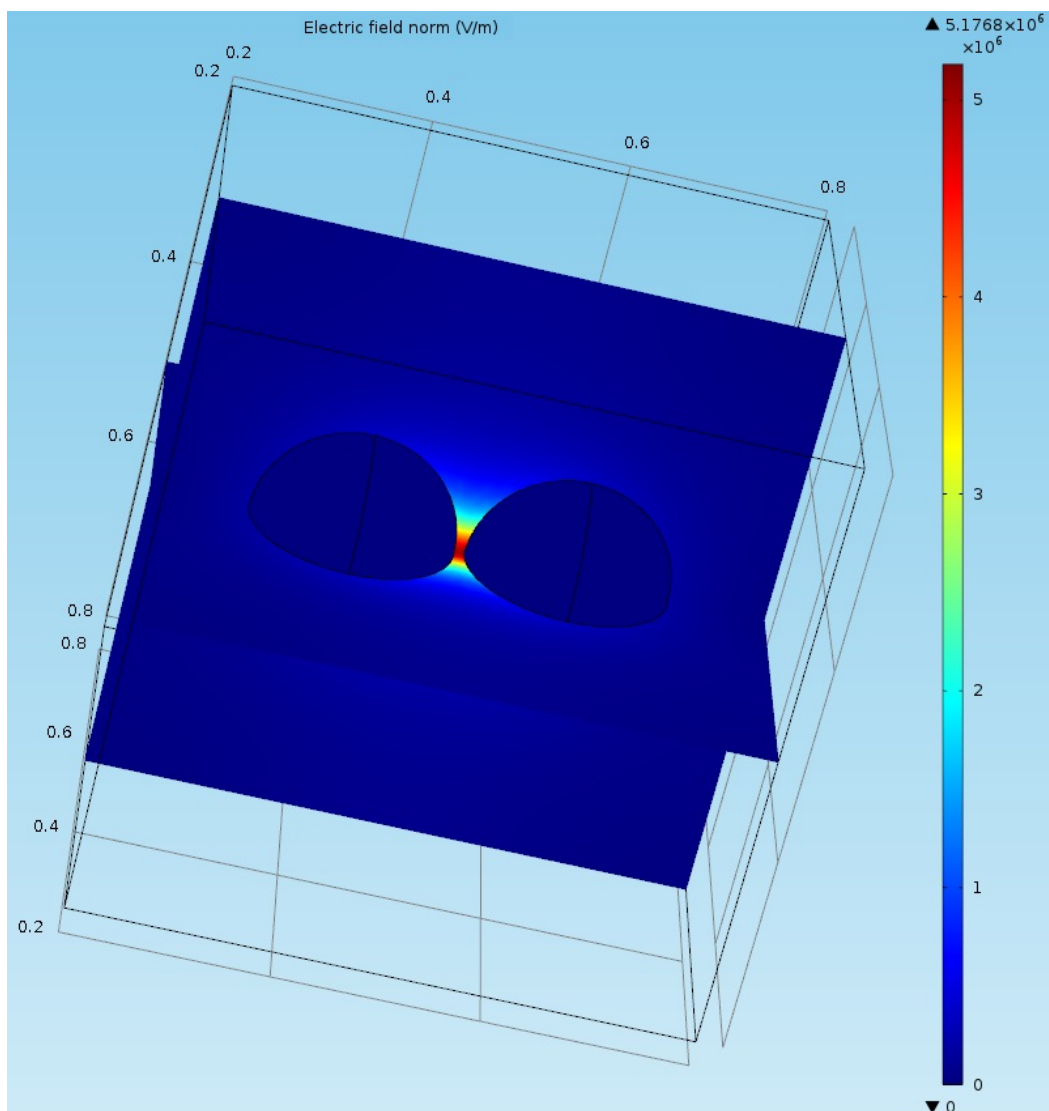

**Fig. 5.** Electric field distribution for the system of eccentric spheres in air.

Similar dependences were obtained also for the other electrode systems like parallel plate electrodes (difference of 2%) and coaxial cylinders (< 1%).

### **Conclusion**

The approach to the problem of determining the maximum value of electrical field stress in the model electrode systems immersed in oil, used in the previous experimental studies, may be recognized as a correct.

Performing the calculations in accordance to the presented approach, will allow, with large probability, on the confirmation of hypothesis about the relationship between the measured during the experimental works times to initiation and the most stressed oil volume law, thus about the important role of oil in the process of electrical discharge initiation in the systems of paper-oil insulation.



*The work was financed by the Polish Ministry of Science and Higher Education on the basis of decision 0464/IP2/2011/71.*

**References:**

- Gafvert U., Jaksts A., Tornkvist Ch., Walfridson L., Electrical field distribution in transformer oil. IEEE Trans. on Electr. Insul. Vol. 27, 1992.
- Raicevic N.B., Electrical field and potential distribution at the cable termination. Intern. Conf. on Electr. Power Eng., 1999.
- Khaligh A., Vakilian M., Power transformers internal insulation design improvements using electric field analysis through finite element methods. IEEE Trans. Magnetics, Vol. 44, 2008
- Ma A. Q., Zhang Z. S., End insulation electric field analysis and design optimization of 500kV power transformer based on ANSYS. IEEE Conf. on Innovative Smart Grid Technologies, 2012.
- Hantsz D., Technology of manufacturing of SF<sub>6</sub> isolated high voltage capacitors (in Polish). M.Sc. thesis, 2010.
- Galczak J., Electrical discharges in transformer oil in set-up of paper insulated electrodes. Archives of Electr. Eng., Vol. XLVIII, 1999.
- Rozga P., Mechanism of electrical discharge development in transformer oil in the setup of insulated electrodes. Intern. Conf. on High Voltage Engineering and Applications, New Orleans, USA, 2010.
- Rozga P., The influence of paper insulation on the prebreakdown phenomena in mineral oil under lightning impulse, IEEE Trans. Diel. Electr. Insul., Vol. 11, 2011.
- Beroual A., Fofana I., Modeling of the streamer in dielectric liquids with an equivalent electrical network. 12<sup>th</sup> Intern. Conf. on Cond. and Breakdown in Diel. Liquids, Roma, Italy, 1996.
- Aka-Ngui T., Beroual A., Modeling of branching streamers propagation within dielectric liquids. Annual Report Conf. on Electr. Insul. and Diel. Phenom., 2001
- Mosinski F., Wodzinski J., Calculation of the volume of strongly stressed oil in a model which takes the edge effect into consideration (in Polish), Scientific Bulletin of the Technical University of Lodz, Elektryka 66, 1979.
- Murano M., Menju S., Ikeda M., Hasegawa N., Inoue T., Experimental extension of volume effect on breakdown of transformer oil. Winter Power Meet. New York, C 74, 1974.